

# Output power enhancement of photovoltaic system using buck-boost converter compared with boost converter by mitigating harmonics in the frequency

Tamil Selvan A<sup>1</sup>, R.Geetha<sup>2</sup>

<sup>1</sup>Research Scholar, Department of Electrical and Electronics Engineering, Saveetha School of Engineering, Saveetha Institute of Medical and Technical Sciences, Saveetha University, Chennai, Tamilnadu. India. Pincode:602105.

<sup>2</sup>Project Guide, Corresponding Author, Department of Electrical and Electronics Engineering, Saveetha School of Engineering, Saveetha Institute of Medical and Technical Sciences, Saveetha University, Chennai, Tamilnadu. India. Pincode: 602105

## Abstract

**Aim:** The major objective of this proposed work is to evaluate the PV-powered buck-boost converter when differentiated from the Boost converter that will make the most efficient use of renewable energy. As a result, this research on the generation and enhancing power flow using a buck-boost converter is presented. **Materials and Methods:** PV system interfaced with a Boost converter and Buck-Boost converter is analyzed. The sample size is calculated as 14 with each group as 7 using GPower software. The significance value is determined as 0.001 ( $p < 0.05$ ) based on SPSS analysis. **Results:** Buck-Boost converter provides an efficiency of 49.78% whereas the conventional Boost converter has 39.41%. The significance value is determined as 0.001 ( $p < 0.05$ , statistically significant) based on SPSS analysis. **Conclusion:** PV-powered buck-boost converter gives more efficiency at a faster pace under varied operating conditions. As a result, this will be a superior platform for generating power and satisfying load demands.

**Keywords:** Novel Buck-Boost Converter, Boost Converter, PV Array, Renewable Energy, Efficiency.

DOI: 10.47750/pnr.2022.13.S03.086

## INTRODUCTION

Transportation energy generation, industrial activities, and heating all need fossil fuels. At the same time, burning fossil fuels to release their chemical energy is a major source of greenhouse gas emissions, primarily carbon dioxide (CO<sub>2</sub>), which contributes to global warming. Solar energy production is one of the most common. While there has been a surge in interest in and use of solar energy as a crucial alternative clean energy source in recent years, solar technology deployment has mostly been focused on power generation (Ogura et al. 2004). Photovoltaic power has acquired increased attention as a way to meet demand due to the high quality of power it provides to residential and industrial clients (Mageshwari, Kanagalakshmi, and Rao 2017). The PV system can be utilized in grid systems, electric vehicles, drive applications, etc., (Raja Mohamed, Aruna Jeyanthi, and Devaraj 2018) (Surosoa 2010)(Raja Mohamed, Aruna Jeyanthi, and Devaraj 2018).

From 1999 to 2021, a large number of research studies have been examined in this regard. Nearly 1283 research works were analyzed, from IEEE and Google Scholar. One of the most crucial components in a solar system is the power converter because it can convert various types of power and generate electricity more compatible with the end-user. Because solar cells generate DC electricity, many types of power converters can be used (Kotak and Tyagi 2013). In this research work (Enrique et al. 2007) comparative of the photovoltaic system performance using the three basic topologies of DC/DC converters and MPPT tracker were discussed. The ambient temperature, as well as the panel's installation type, will have an impact on the temperature derating. The effects of insolation on PV panel performance if the ambient temperature is 28°C were calculated using the PSPICE/MATLAB model and published (Gow and Manning 1999). It is critical to operate the solar panel at its ideal PowerPoint to optimize the power generated. As a result, a power electronics converter interface is introduced between a solar panel and a battery. To extract the most power from a PV solar panel, numerous pulse width modulator (PWM) DC-DC converters are used (Baharudin et al. 2017).

Our team has extensive knowledge and research experience that has translate into high quality publications(Bhansali et al. 2021; Jayanth et al. 2021; Sudhakar, Ravel, and Perumal 2021; Sathiyamoorthi et al. 2021; Deepanraj et al. 2021; Raju et al. 2021; Arun Prakash et al. 2020; Kamath et al. 2020; Shanmugam et al. 2021; Rajasekaran et al. 2020; Adhinarayanan et al. 2020; Rajesh et al. 2020; Aurtherson et al. 2021). The limitation of the existing topology is that due to change in frequency the output voltage is also varied which influences the system performance. The aim of this research work is to interface a novel buck-boost converter in which voltage fluctuations are limited with varying frequency so that system performance will be improved.

## Materials And Methods

This research was done in the Power Electronics Lab, Department of Electrical and Electronics Engineering, Saveetha School of Engineering, Saveetha Institute of Medical And Technical Sciences. Two topologies have been compared and its sample size has been calculated by using G power software. It was determined that each method has 7 samples and a total of 14 samples (g power setting parameters:  $\alpha=0.05$ , power=0.80, effect size  $d=0.2$ ). The system is simulated using the MATLAB Simulink software.

Energy generation, conversion, transmission, and distribution all rely heavily on power electronic devices. AC-DC, DC-DC, DC-AC, and AC-AC conversion systems all utilize it. Semiconducting devices play a role in DC-DC-AC conversion in grid-connected systems. The role of a DC-DC converter in a PV-powered system is critical, and it focuses on increasing voltage. The voltage received from the source can be stepped up or decreased using DC-DC converters. For DC-DC conversion, a wide range of converters are available, however, the buck, boost, and buck-boost stages are the most common. The duty ratio given to the switches determines how well these various converters work. Researchers have proposed a specific construction for converters to take low input magnitudes and acquire bigger voltage magnitudes with a lower duty ratio and lessen stresses between switches in recent years. Following previous research into enhancing the voltage gain of PV arrays, two distinct converter architectures with PV as an input source were chosen for analysis. Our team has extensive knowledge and research experience that has translate into high quality publications(Bhansali et al. 2021; Jayanth et al. 2021; Sudhakar, Ravel, and Perumal 2021; Sathiyamoorthi et al. 2021; Deepanraj et al. 2021; Raju et al. 2021; Arun Prakash et al. 2020; Kamath et al. 2020; Shanmugam et al. 2021; Rajasekaran et al. 2020; Adhinarayanan et al. 2020; Rajesh et al. 2020; Aurtherson et al. 2021)

PV farm, the converter, then dc-link capacitor, voltage source inverter, maximum power point controller (MPPT), PWM control unit, filters, and some other main control circuits make up a grid-connected PV system(Singh and Rajput 2016). Its function can be divided into two categories: ON and OFF(Grinkevich and Troitskiy 2003). Switch T is on in the ON state, and the entire current flows via the inductor, circling in a loop, with no current flowing through the diode. Switch T is opened in the OFF state, allowing the total current to flow by diode D, capacitor C, and resistance R. At the converter output, the control loop keeps a 500V dc output voltage.

From this article, various models of PV systems with several DC-DC converter methodologies are used, such as well as buck converters, boost converters, and buck-boost converters, that are implanted to cut the power gap between the Novel PV array and the load by changing the duty cycle, a proceeding known as greatest power point tracking (MPPT). This study discusses four alternative MPPT-controlled DC-DC converter approaches. The whole first approach has been suggested, which comprises a PV module linked to a buck-boost converter regulated by an incremental conductance MPPT algorithm, as well as a PID controller to minimize output voltage inaccuracy. The second approach is identical to the above but does not include a PID controller. The latter two systems use a boost converter with MPPT control and PWM technology. Matlab/Simulink is used to simulate all of the approaches described (Mao et al. 2017).

## Statistical Analysis

Statistical analysis is done by using SPSS tools and for obtaining the performance of the Boost converter and buck Boost converter. The statistical features such as mean, standard deviation, and standard mean error are obtained for both the topologies using the statistical tools. Frequency is the independent variable and Harmonics is a dependent variable. Independent T-test analysis is performed in this research work.

## Results

The recommended system procedure yielded Table 1 represents 0.2141 standard deviations and 0.08142 value of standard error, whereas the conventional method yielded 1.38223 standard deviations and 0.52243 as standard error. Table 2 shows a T-test analysis of conventional and proposed methods when the THD was varied from  $5e^3$  to  $25e^3$ . The mean value of the system employing buck-boost converter is 49.7800, which is higher than

the mean value of the boost converter having 39.4143. Table 3 reveals a wide variation in output power and efficiency among recommended and existing systems based on an Independent Samples Test. Considering  $p < 0.05$ , there is a substantial variation among the two groups (t value is -9.07110.201). The quality significance variation among the two groups is 0.001 ( $p < 0.05$ , statistically significant).

Figures 1 and 2 show the generalized structure of the PV array with boost and buck-boost converter. With irradiance and temperature level of 1000 and 25 degrees, Celsius is fixed for both existing and proposed methods to analyze the efficiency. Other than efficiency, the amount of power gained from the network is essential. So both studies will concentrate upon improving the voltage gain. Figures 3 and 4 represent the voltage and current obtained from the PV-connected boost converter and buck-boost converter. The total harmonics involved in it could define the power quality. So all the steps handled in the proposed study are to take care upon reduction in noise, unwanted interruption of signals, harmonics, etc. Figure 5 depicts a comparison of peak output power and efficiency gained from the usual system and the suggested way. With a standard deviation range, the suggested technique can generate more consistent findings.

## Discussions

PV interfaced novel Buck-Boost and Boost converters were implemented to improve the efficiency under the varying frequency. From the obtained results, the novel buck-boost (49.78%) converter produces better efficiency compared to the boost converter (39.41%).

Numerous studies have been conducted on PV-powered conversion systems combined with storage systems to meet load requirements, as well as alternative topologies for utilizing solar energy or grid-connected PV systems. Understanding all of the steps taken and carried out in each technique is fairly necessary. Sustainable and renewable energy processing, portable devices, and many industrial processes all used DC-DC converters (Qiao *et al.* 2006). The duty ratio is the major factor to determine the functioning of the converter (Bharadwaj and John 2014) It is mostly used to obtain a constant DC voltage from a DC source such as a rectifier output, a battery, or a solar cell (Margaret *n.d.*), which is then delivered to a DC-DC converter. Several conversions are done to inject the generated voltage into the grid (Mostafa, Saad, and El-sattar 2020). The proposed system can generate limited power only because the storage system is unavailable (Ogudo and Umenne 2019). By introducing additional storage the energy generated will be stored and used for the future (Dagal and Akin 2019).

The increase in demand for power kept increasing as like increase in population and growth of industrial sectors. It is insufficient to meet the energy crisis in the future. This will cause lagging in power generation. Adding an energy storage system will improve in meeting the power demand without any lag. This method will be a great choice in the future when the storage system is assisted.

## Conclusion

In this work, higher efficiency of the PV system was carried out in both novel Buck-Boost converter and conventional Boost converter. It is inferred from the obtained results that a Buck-Boost converter has a better efficiency of 39.41% compared to a conventional Boost converter has a voltage gain of 49.78%. Based on the independent T test the significance value is 0.001 ( $p < 0.05$ ) statistically significant within the limit of study.

## DECLARATIONS

### Conflicts of Interest

No conflict of interest in this manuscript.

### Author Contributions

Author ATS was involved in data collection, data analysis, and manuscript writing, and author RG was involved in conceptualization, data validation, and critical review of the manuscript.

### Acknowledgments

The authors would like to express their gratitude towards Saveetha School of Engineering, Saveetha Institute of Medical and Technical Sciences (Formerly known as Saveetha University) for providing the necessary infrastructure to carry out this work successfully.

**Funding:** We thank the following organizations for providing financial support that enabled us to complete the study.

1. AJS Engineering Pvt Ltd, Chennai, India
2. Saveetha University
3. Saveetha Institute of Medical and Technical Sciences
4. Saveetha School of Engineering

## References

1. Adhinarayanan, Rajesh, Aravindh Ramakrishnan, Gopal Kaliyaperumal, Melvin Victor De Pours, Rajesh Kumar Babu, and Damodharan Dillikannan. 2020. "Comparative Analysis on the Effect of 1-Decanol and Di-N-Butyl Ether as Additive with diesel/LDPE Blends in Compression Ignition Engine." *Energy Sources, Part A: Recovery, Utilization, and Environmental Effects*, June, 1–18.
2. Arun Prakash, V. R., J. Francis Xavier, G. Ramesh, T. Maridurai, K. Siva Kumar, and R. Blessing Sam Raj. 2020. "Mechanical, Thermal and Fatigue Behaviour of Surface-Treated Novel Caryota Urens Fibre-reinforced Epoxy Composite." *Biomass Conversion and Biorefinery*, August. <https://doi.org/10.1007/s13399-020-00938-0>.
3. Aurtherson, P. Babu, Bhanu Teja Nalla, Karthikeyan Srinivasan, Kulmani Mehar, and Yuvarajan Devarajan. 2021. "Biofuel Production from Novel Prunus Domestica Kernel Oil: Process Optimization Technique." *Biomass Conversion and Biorefinery*, May. <https://doi.org/10.1007/s13399-021-01551-5>.
4. Baharudin, Nor Hanisah, Tunku Muhammad Nizar Mansur, Fairuz Abdul Hamid, Rosnazri Ali, and Muhammad Irwanto Misrun. 2017. "Topologies of DC-DC Converter in Solar PV Applications." *Indonesian Journal of Electrical Engineering and Computer Science* 8 (2): 368–74.
5. Bhansali, Karan J., Kamlesh R. Balinge, Subodh U. Raut, Shubham A. Deshmukh, M. Senthil Kumar, C. Ramesh Kumar, and Pundlik R. Bhagat. 2021. "Visible Light Assisted Sulfonic Acid-Functionalized Porphyrin Comprising Benzimidazolium Moiety for Photocatalytic Transesterification of Castor Oil." *Fuel* 304 (November): 121490.
6. Bharadwaj, Pallavi, and Vinod John. 2014. "Direct Duty Ratio Controlled MPPT Algorithm for Boost Converter in Continuous and Discontinuous Modes of Operation." *IISC*, 6.
7. Dagal, Idriss, and Burak Akin. 2019. "ENERGY TRANSFER FROM THE PV PANEL TO BATTERY VIA BUCK-BOOST CONVERTER." *MATTER: International Journal of Science and Technology* 5 (3): 46–60.
8. Deepanraj, B., N. Senthilkumar, D. Mala, and A. Sathiamourthy. 2021. "Cashew Nut Shell Liquid as Alternate Fuel for CI Engine—optimization Approach for Performance Improvement." *Biomass Conversion and Biorefinery*, February. <https://doi.org/10.1007/s13399-021-01312-4>.
9. Enrique, J. M., E. Durán, M. Sidrach-de-Cardona, and J. M. Andújar. 2007. "Theoretical Assessment of the Maximum Power Point Tracking Efficiency of Photovoltaic Facilities with Different Converter Topologies." *Solar Energy* 81 (1): 31–38.
10. Gow, J. A., and C. D. Manning. 1999. "Development of a Photovoltaic Array Model for Use in Power-Electronics Simulation Studies." *IEE Proceedings - Electric Power Applications* 146 (2): 193–200.
11. Grinkevich, D. J., and A. V. Troitskiy. 2003. "Methods of Control by DC/DC Boost Converter." In *7th Korea-Russia International Symposium on Science and Technology, Proceedings KORUS 2003. (IEEE Cat. No.03EX737)*, 2:468–73 vol.2.
12. Jayanth, Bellappu Venkat, Melvin Victor Depoures, Gopal Kaliyaperumal, Damodharan Dillikannan, Dilipsingh Jawahar, Kumaran Palani, and Ganesha Prasad Meravanigee Shivappa. 2021. "A Comprehensive Study on the Effects of Multiple Injection Strategies and Exhaust Gas Recirculation on Diesel Engine Characteristics That Utilize Waste High Density Polyethylene Oil." *Energy Sources, Part A: Recovery, Utilization, and Environmental Effects*, June, 1–18.
13. Kamath, Manjunath, Subha Krishna Rao, Jaison, Sridhar, Kasthuri, Gopinath, Sivaperumal, and Shantanu Patil. 2020. "Melatonin Delivery from PCL Scaffold Enhances Glycosaminoglycans Deposition in Human Chondrocytes – Bioactive Scaffold Model for Cartilage Regeneration." *Process Biochemistry* 99 (December): 36–47.
14. Kotak, V. C., and Preti Tyagi. 2013. "DC To DC Converter in Maximum Power Point Tracker." *International Journal of Advanced Research in Electrical, Electronics and Instrumentation Engineering* 2 (12): 11.
15. Mageshwari, Sannasy, S. Kanagalakshmi, and Hannumath Rao. 2017. "Design and Implementation of Buck-Boost Converter for Residential PV Application." *International Journal on Electrical Engineering and Informatics* 9: 16.
16. Mao, Mingxuan, Qichang Duan, Li Zhang, Hao Chen, Bei Hu, and Pan Duan. 2017. "Maximum Power Point Tracking for Cascaded PV-Converter Modules Using Two-Stage Particle Swarm Optimization." *Scientific Reports* 7 (1): 9381.
17. Margaret, S. Radhika And. n.d. "A Review on DC-DC Converters with Photovoltaic System in DC Micro Grid." Accessed October 31, 2021. <https://iopscience.iop.org/article/10.1088/1742-6596/1804/1/012155/pdf>.
18. Mostafa, Mostafa R., Naggat H. Saad, and Ahmed A. El-sattar. 2020. "Tracking the Maximum Power Point of PV Array by Sliding Mode Control Method." *Ain Shams Engineering Journal* 11 (1): 119–31.
19. Ogudo, Kingsley A., and Patrice Umenne. 2019. "Design of a PV Based Power Supply with a Non Inverting Buck-Boost Converter." In *2019 IEEE PES/IAS PowerAfrica*, 545–49.
20. Ogura, K., T. Nishida, E. Hiraki, M. Nakaoka, and S. Nagai. 2004. "Time-Sharing Boost Chopper Cascaded Dual Mode Single-Phase Sinewave Inverter for Solar Photovoltaic Power Generation System." In *2004 IEEE 35th Annual Power Electronics Specialists Conference (IEEE Cat. No.04CH37551)*, 6:4763–67 Vol.6.
21. Qiao, Haibo, Yicheng Zhang, Yongtao Yao, and Li Wei. 2006. "Analysis of Buck-Boost Converters for Fuel Cell Electric Vehicles." In *2006 IEEE International Conference on Vehicular Electronics and Safety*, 109–13.
22. Raja Mohamed, S., P. Aruna Jeyanthi, and D. Devaraj. 2018. "Hysteresis-Based Voltage and Current Control Techniques for Grid Connected Solar Photovoltaic Systems: Comparative Study." *International Journal of Electrical, Computer, and Systems Engineering* 8 (5): 2671–81.
23. Rajasekaran, S., D. Damodharan, K. Gopal, B. Rajesh Kumar, and Melvin Victor De Pours. 2020. "Collective Influence of 1-Decanol Addition, Injection Pressure and EGR on Diesel Engine Characteristics Fueled with diesel/LDPE Oil Blends." *Fuel* 277 (October): 118166.
24. Rajesh, A., K. Gopal, De Pours Melvin Victor, B. Rajesh Kumar, A. P. Sathiyagnanam, and D. Damodharan. 2020. "Effect of Anisole Addition to Waste Cooking Oil Methyl Ester on Combustion, Emission and Performance Characteristics of a DI Diesel Engine without Any Modifications." *Fuel* 278 (October): 118315.
25. Raju, P., K. Raja, K. Lingadurai, T. Maridurai, and S. C. Prasanna. 2021. "Glass/Caryota Urens Hybridized Fibre-Reinforced nanoclay/SiC Toughened Epoxy Hybrid Composite: Mechanical, Drop Load Impact, Hydrophobicity and Fatigue Behaviour." *Biomass Conversion and Biorefinery*, March. <https://doi.org/10.1007/s13399-021-01427-8>.
26. Sathiyamoorthi, Ramalingam, Gomathinayakam Sankaranarayanan, Dinesh Babu Munuswamy, and Yuvarajan Devarajan. 2021. "Experimental Study of Spray Analysis for Palmarosa Biodiesel-diesel Blends in a Constant Volume Chamber." *Environmental Progress & Sustainable Energy* 40 (6). <https://doi.org/10.1002/ep.13696>.

27. Shanmugam, Rajasekaran, Damodharan Dillikannan, Gopal Kaliyaperumal, Melvin Victor De Poures, and Rajesh Kumar Babu. 2021. "A Comprehensive Study on the Effects of 1-Decanol, Compression Ratio and Exhaust Gas Recirculation on Diesel Engine Characteristics Powered with Low Density Polyethylene Oil." *Energy Sources, Part A: Recovery, Utilization, and Environmental Effects* 43 (23): 3064–81.
28. Singh, Omveer, and Saurabh Kumar Rajput. 2016. "Mathematical Modelling and Simulation of Solar Photovoltaic Array System." In *2016 International Conference on Research Advances in Integrated Navigation Systems (RAINS)*, 1–5. [ieeexplore.ieee.org](http://ieeexplore.ieee.org).
29. Sudhakar, M. P., Merlyn Ravel, and K. Perumal. 2021. "Pretreatment and Process Optimization of Bioethanol Production from Spent Biomass of *Ganoderma Lucidum* Using *Saccharomyces Cerevisiae*." *Fuel* 306 (December): 121680.
30. Suroso, Toshihiko Noguchi. 2010. "A New Three-Level Current-Source PWM Inverter and Its Application for Grid Connected Power Conditioner." *Energy Conversion & Management* 51 (7): 9.

## TABLES AND FIGURES

**Table 1.** Efficiency of the novel Buck-boost the buck-boost converter and the conventional Boost converter for varying frequency

Frequency (Hz)	Efficiency (%)	
	Buck-boost converter	Boost converter
5000	49.43	37.65
7000	49.60	38.03
10000	49.71	38.50
17000	49.92	39.60
22000	49.80	40.20
25000	49.97	40.67
30000	50.03	41.25

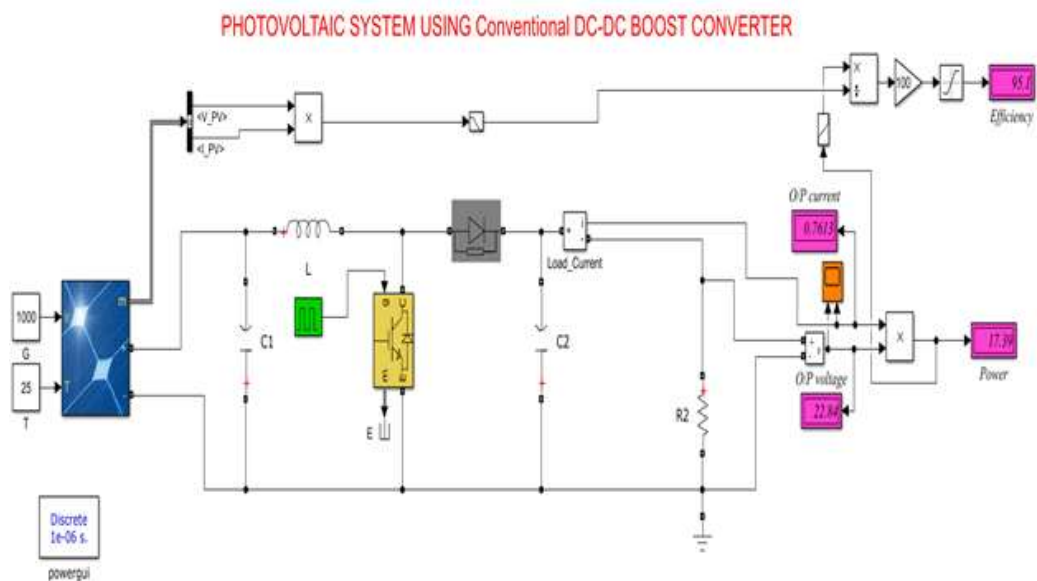
**Table 2.** Group statistical analysis of novel Buck-boost converter and conventional Boost Converter by taking 7 variables per group. The standard error mean for the modified sepic converter is .08142 and for the conventional sepic converter is 0.52243. Efficiency calculation of using seven samples selected for each group.

Group Statistics					
	GROUP NAME	N	Mean	Standard Deviation	Standard Error Mean

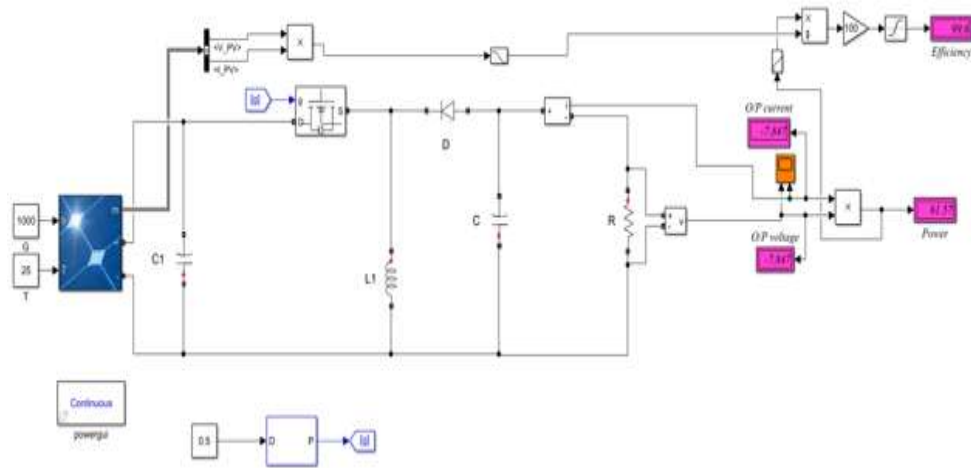
<b>Efficiency</b>	<b>Buck-boost converter</b>	7	49.7800	.2141	.08142
	<b>Boost converter</b>	7	39.4143	1.38223	.52243

**Table 3:** The independent sample test revealed a substantial variation inefficiency among the suggested two stages and the standard single stage. Since the value of significance is 0.001  $p < 0.05$ , there is a substantial variation among the two methods, which is considered to be statistically significant.

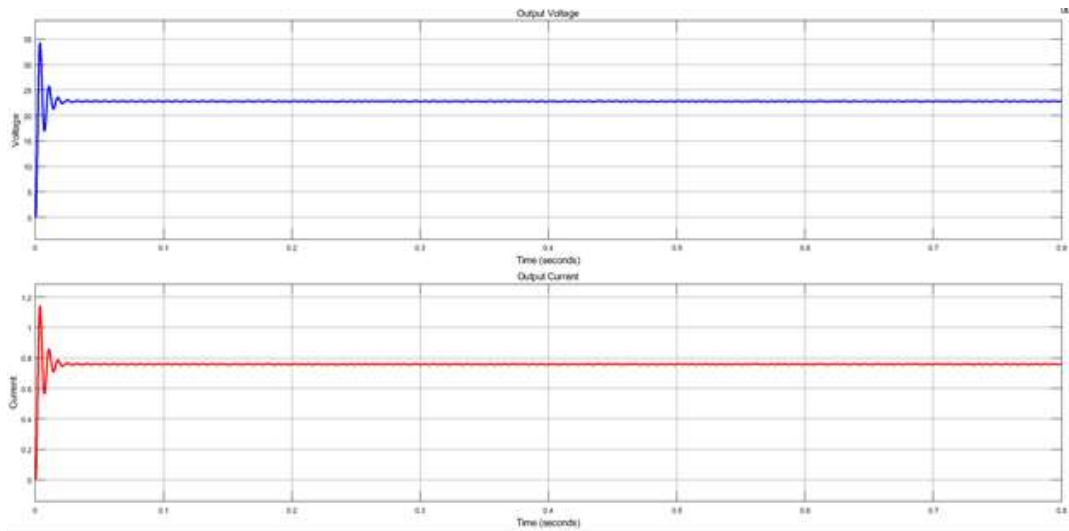
Independent Sample Test										
Levene's Test for Equality of Variances				T-test for Equality of Means						
		F	Sig.	T	Df	Sig. (2-tailed)	Mean Difference	Std. Error Differences	95% Confidence Interval of the Difference	
									Lower	Upper
<b>Efficiency</b>	<b>Equal Variances assumed</b>	19.54	.001	19.605		.000	10.365	.52874	9.21369	11.5177
	<b>Equal Variances not assumed</b>			19.605	6.291	.000	10.365	.52874	9.08632	11.6451



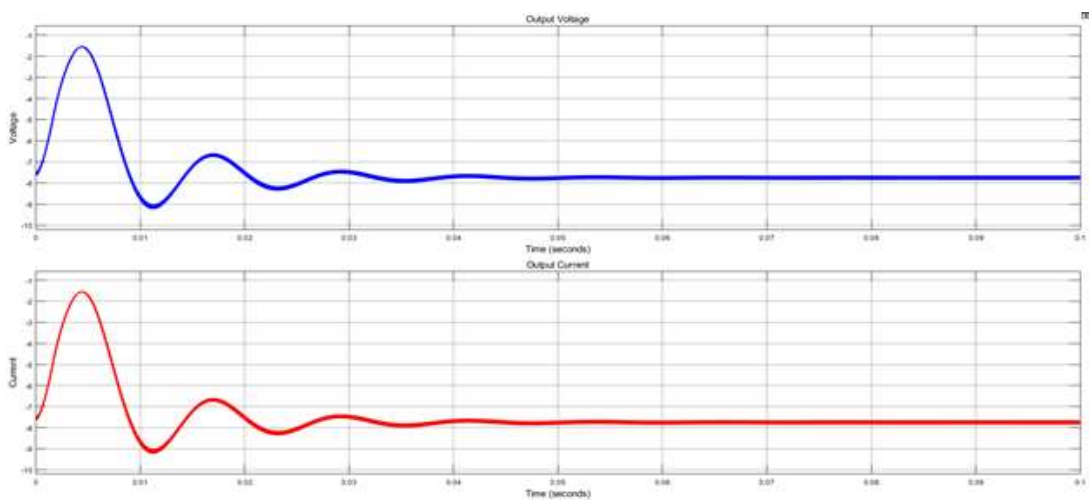
**Fig. 1.** Simulink diagram of the PV interfaced Boost converter .



**Fig. 2.** Simulink diagram of the buck-boost converter interfaced with PV system

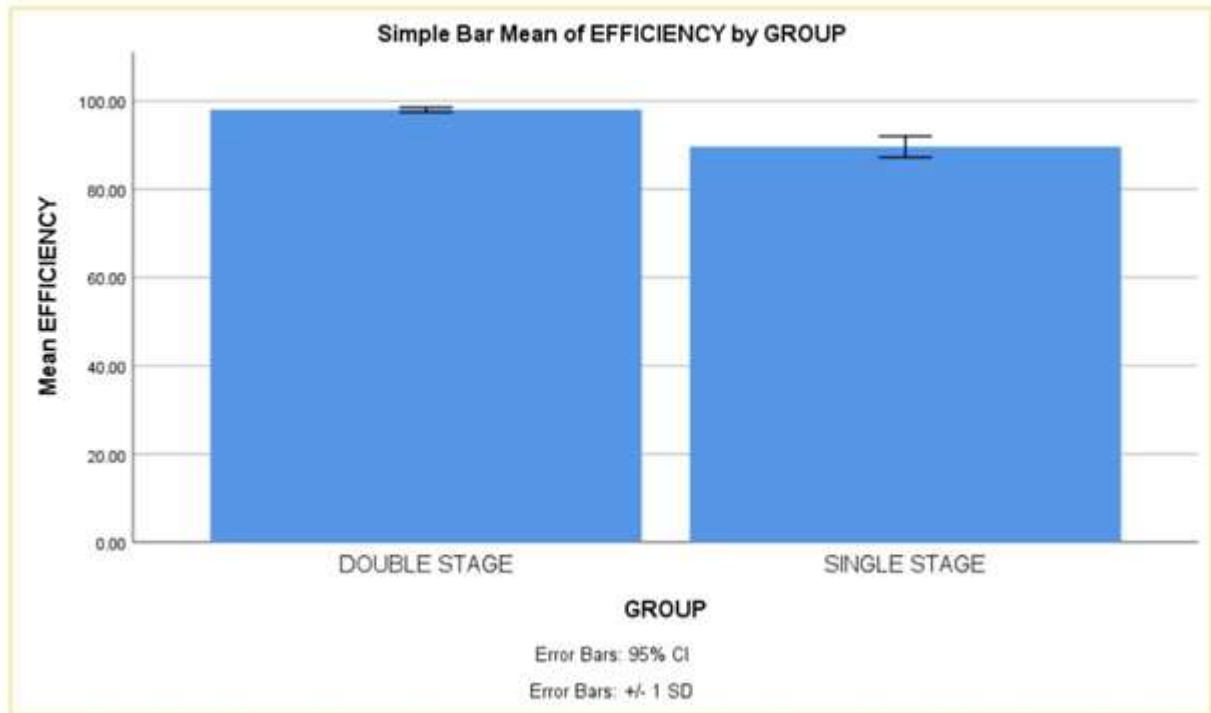


**Fig. 3.** Voltage and current gain of boost converter system measured across a load



**Fig. 4.** Voltage and current gain of buck-boost converter system measured across a load

GGraph



**Fig. 5.** Comparison of Boostconverter with buck-boost converter method in terms of Mean output and efficiency is presented. The output of the buck-boost converter and boost converter and the standard deviation of the buck-boost converter is slightly better than the conventional boost converter. X-Axis: novel buck-boost vs boost converter. Y-Axis: Mean Harmonics of detection is  $\pm 1$  SD.