

# AUTOMATIC FIRE DETECTION, INDICATION AND CONTROLLING SYSTEM FOR COMMERCIAL BUILDING USING PROGRAMMABLE LOGIC CONTROLLER

Haroon Ali Khan<sup>1</sup>, Gaddam Kalpana<sup>2</sup>, G.Nishanthi<sup>3</sup>, N. R. Aarthi<sup>4</sup>

<sup>1</sup>Assistant Professor, Department of Civil Engineering, Velagapudi Ramakrishna Siddhartha Engineering College, Vijayawada, Andhra Pradesh, INDIA.

E-mail ID - [haroon@vrsiddhartha.ac.in](mailto:haroon@vrsiddhartha.ac.in)

<sup>2</sup>Assistant Professor, Department of Civil Engineering, vikas college of engineering and technology, nunna loyabata road, ntr district, Andhra Pradesh, INDIA.

E-mail ID - [kappu.kalpana54@gmail.com](mailto:kappu.kalpana54@gmail.com)

<sup>3</sup>Assistant Professor, RMK Engineering College, College address: RSM Nagar, Gummidipoondi, Taluk, Kavaraipettai, Tamil Nadu, India.

E-mail ID: [nishanthig06@gmail.com](mailto:nishanthig06@gmail.com)

<sup>4</sup>Assistant Professor, Instrumentation Engineering, Panimalar Engineering College, Tamil Nadu, India.

E-mail ID - [aarthi316@gmail.com](mailto:aarthi316@gmail.com)

DOI: 10.47750/pnr.2023.14.02.392

## Abstract

In urban architecture, the lives and belongings of people begin to cause enormous casualties. An automatic fire alarm system is used to detect the fire in the house. This paper explores the framework for automatic fire warning, composition, and functioning. The fire warning system is a mix of several systems that work together to identify and alert people when smoke is a fire utilizing visual and auditory devices. Smoke sensors or heat sensors may trigger the alarm used in the fire alarm system. Alarms may either be engine bells or sounders or horns mountable on a wall. In keeping and controlling secure conditions and situations of all kinds, the fire alarm system plays a major role. However, it is understood that many modern fire alarms and detection systems can be operated at high costs. The device is collected by the fire alert sensor for fire, failure, and other signals that are sent to the submachine, The re-transmission of such data will be sent to the fire alarm control and then the controller, sound, and light alarm monitor, alarm and other equipment will start. The main aim of this Fire Alarm Management System is to create a fire control and deletion system with cost reliability in building automation using PLC. The BASS fire alarm control system has three major systems: (1) fire warning, (2) alarm and control, and (3) the equipment to open the door and the lift to the ground for security purposes. The fire detector is the warning machine. This machine has elements, such as a flame sensor, a smoke detector, and a heat detector, including bimetallic strips. The key aim of the analysis was the assembly of a PLC-based fire alarm system with a programmable logic controller and its output in the field of smoke and heat detection and its effect on the automatic alarm and sprinkling (PLC). For control and extinguishing of fires, this device is the most powerful.

**Keywords:** PLC, Fire detection, Siren, Sprinkler, Smoke detector, Pump.

## Introduction

Fire warning systems are equipped to identify fires early on when the time for the safe escape of inhabitants will still be possible. To ensure the welfare of emergency response workers early warning also plays an integral part.

The loss of property can be limited by early warning and downtime minimized by control efforts begun as a result of a still minor burn. Most warning systems provide emergency responders with information about fire sites, speeding up the fire control process. Detectors can be combined with alarms to be useful. At least building tenants are notified by alarm devices which normally send a signal on or off-site to a staffed control center. In some cases, warnings can reach the fire department directly, but this is no longer the traditional solution in most areas. As discussed above, these devices have many benefits. It does not absorb or power the flames but is the main restriction. The fire is regulated by deleting systems such as automated sprinklers. They also inform them that they operate so that they can fulfill the function of a heat detection system as it is linked to warning devices in the building. However, they do not work as fast as a smoke detector machine. For this reason, also fitted with sprinklers, systems where rapid notification is necessary to do require detection and alarms. Fire has been a source of relief and tragedy for mankind for longer than written history. Fire is a quick, self-supporting mechanism of oxidation followed by heat and light evolution at various intensities. Both fire incidents can be divided in different ways, but there are typically two kinds of fire, one natural and another human. Industrial fires will lead to overheating of equipment as a result of combustion, for either natural or man-made reasons. Nowadays, the majority of fire alarm systems are self-operating, and most fire reports are made over the phone, which implies that the promptness of response cannot be guaranteed in most cases. A large portion of the working day is spent without any attention being paid to fire alarm systems. When a system is not effectively maintained, it can lead to management and maintenance defects [1]. In today's fire safety system [2], the fire alarm is the most important component to have]. The capability of the monitoring center, on the other hand, is a source of contention. Whenever a fire breaks out, it is critical that those who are at risk flee the scene as quickly as possible. Paper [3] will be used to demonstrate the operation of a smart fire safety system in a structure. In response to the author's programming, the building's sprinklers will be activated, which will trip the circuit and activate the sprinklers. Exhaust fans will be used to ventilate the building and eliminate the smoke. It is feasible to save a huge number of people who are trapped in a burning building by employing this method of rescue. Another advantage of this strategy is that it may be used on both new construction and existing structures. To avoid having to make changes to the structure's construction. There will also be a reduction in the cost of implementation.

Thousands of people have lost their lives and their property as a result of the massive losses caused by flames in modern buildings. It was determined that automatic fire alarm systems would be required to reduce the likelihood of a fire breaking out in the structure. The author [4] provides a comprehensive discussion of the design and functioning of an automatic fire alarm system. As soon as a fire alarm is activated, information from the system is transferred to the sub-machine, where it is collected and analyzed. Such information will, for example, be relayed to the fire alarm controller, which will, in turn, activate all of the equipment listed above, as well as a printer if applicable. Using intelligent monitoring systems, the research [5] examines the causes of fire propagation in high-rise buildings. As China's economy has risen fast since the country's opening up to the world in the 1970s, the construction of high-rise structures has increased dramatically in recent years. The likelihood of many people dying or being seriously injured in a fire in a high-rise building is great, as is the likelihood of the extensive property being destroyed. In high-rise buildings all across the world, fires erupt on an annual basis. With the help of a combination of smart building technologies, a system for data-driven analysis and intelligent platform-based assistance was established. Using SCADA (supervisory control and data acquisition) and PLC software, the researchers [6] investigated the design of a hospital's fire alarm and detection system (supervisory control and data acquisitions). It implies that if a fire breaks out on any floor of the hospital, it will be able to detect it in its early stages thanks to the smoke and heat produced by the blaze. A malfunction occurs in the hospital, and if something goes wrong, the detector and system will react following the PLC addressing scheme.

An embedded system-based technique for intellectualized fire monitoring is presented in this research [7] as a solution to the issues that arise from fire reporting. Fire automated alarm system monitoring, remote communication with the administration center, receiving orders from the center, and audio and visual connection to the center is the primary functions of the monitor. Additionally, this paper outlines how multi-thread embedded software development can be used to create an intelligent fire monitoring terminal. For major public buildings, a set of safety recommendations or even dynamic emergency evacuation systems are required. This study [8] proposes an emergency evacuation system for big public buildings based on intelligent buildings and embedded systems, with the primary goal of reducing fire accidents in high-rise structures. This technology is

designed to assist the user and provide real-time updates on the location via an Android app. According to the article [9], intelligent control of wildfire spread within warehouses is advocated. Warehouses are capable of storing a large range of commodities and are equipped with a variety of features. The warehouses might range in size and layout depending on the products that are stored there. Warehouse automation is dependent on the amount of storage space available and the retrieval method in place. The design of a warehouse's fire protection system is influenced by several factors, including the size of the building, its height, the type of storage used, and local norms and regulations. The employment of a PLC-based system to regulate the water curtain nozzles in warehouses is recommended as a means of preventing the rapid spread of wildfires.

In the study [10], SCADA was utilized to build an automatic fire extinguishing system for five forest parts with a total area of up to 5 hectares. As soon as there is a fire in the system, the smoke sensor is activated, and the IP camera footage from the affected area is displayed on the computer's monitor. Residents may flush their toilets with pressurized water from a flushing tap that rotates 360 degrees. If the automatic operation of the water flushing tap is not desired, it is possible to regulate the tap manually. The researcher [11] discusses the hardware of the control system. The frequency converter, asynchronous motor, and encoder for measuring speed are chosen based on the true speed range and load of the original DC speed control system. The fault monitoring device's online monitoring system includes intelligent capacitors, power information gathering terminals, and a host computer. The power information collecting terminal uses an RS485 communication line to collect operational and alarm information for each capacitor, which is then uploaded over GPRS to the upper computer's host station. The concrete mixing facility was regularly upgraded and improved throughout the recent surge in infrastructure construction. Currently, concrete mixing stations can be controlled in three ways: by relay, PLC, or a single-chip microprocessor. The PLC-controlled mixing station provides dependable performance at a high cost to ensure the quality and efficiency of concrete production. The control of a concrete mixing station is investigated in the study [12].

The research article is carried out in the below ways. In subdivision 2 the block diagram of fire detection and alerting in multichannel is discussed. The workflow of designing the proposed method is also deliberate using the ladder diagram. The working of the entire system is checked in subdivision 3 by the manually smoke detector. Subdivision 4 concludes the designed system benefits and gives the idea to enhance the present work.

## Methodology

### A. System Representation

The proposed system consists of three stages. One is detecting the fire, the second one is making the people alert and the final stage is controlling the fire. In the first stage, the smoke detector detects the fire in the early stage. After detecting the fire, the alarm should give to the persons at the building for alerting them. Then the exit door should open to make the people escape. And at the same time, it is a must to make the lift to come on the ground floor. Because many people are trying to use the lift at the time of the fire but it is not safe to use the lift at this time. Then the final stage is controlling the fire. For fire control, the sprinkler is used to spray the water in the fired area. The block diagram of multi-channel fire alarm detection is shown in figure 1. Then the flow chart of the proposed system is given in figure 2.

FIGURE 1. Block Diagram of the Proposed System

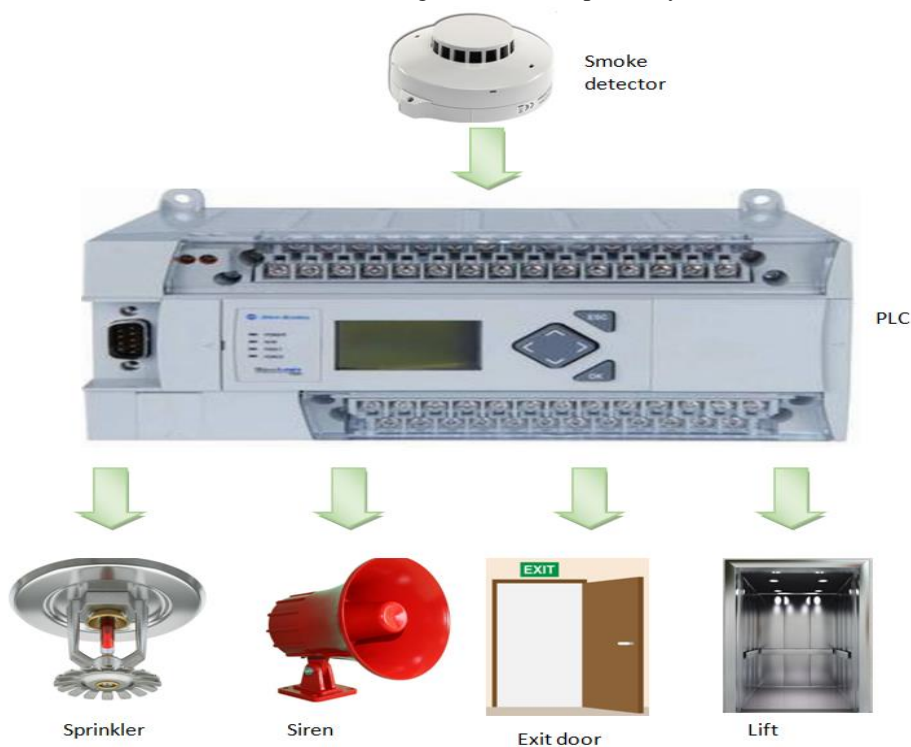
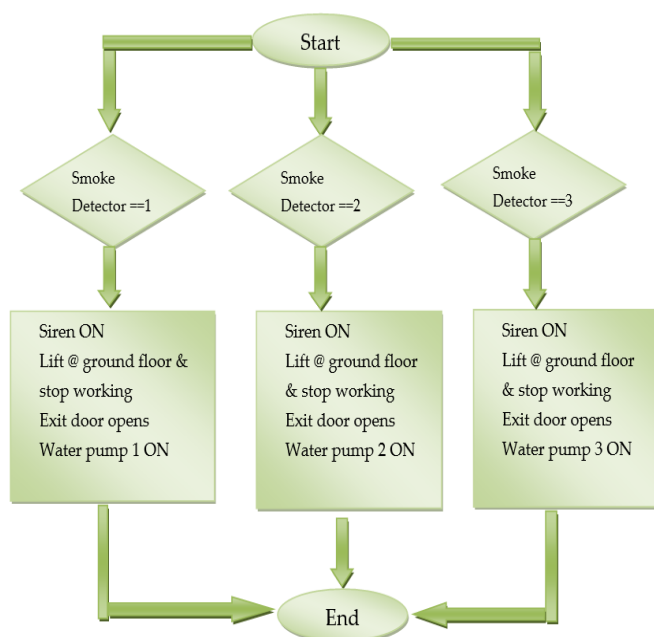

FIGURE 2. Flowchart of the proposed system



There are three phases of the proposed system. One detects the fire; the other alerts people and controls the fire at the ultimate moment. The smoke detector in the initial stage is to identify the smoke. The alarm should be sent to the people in the building to notify them after the fire has been detected. To get the people out, the exit door can then be opened. And the elevator must be made on the ground floor at the same time. Since several people want to use the elevator while the fire is on, the elevator is not safe at this moment. Then the fire is regulated by the final level. The sprinkler is used for fire protection in the fired area to rain the water. Figure 3 shows the lift operating condition. If the ground floor switch is pressed the lift comes to the ground floor even the lift present

on any floor like 1st and 2nd floor. As if the 1st-floor switch is pressed the lift comes to the first floor even the lift present in any floor like the ground or 2nd floor. And if the 2nd-floor switch is pressed the lift comes to the second floor even the lift present in any floor like 1st and ground floor.

FIGURE 3. PLC PROGRAM PART 1

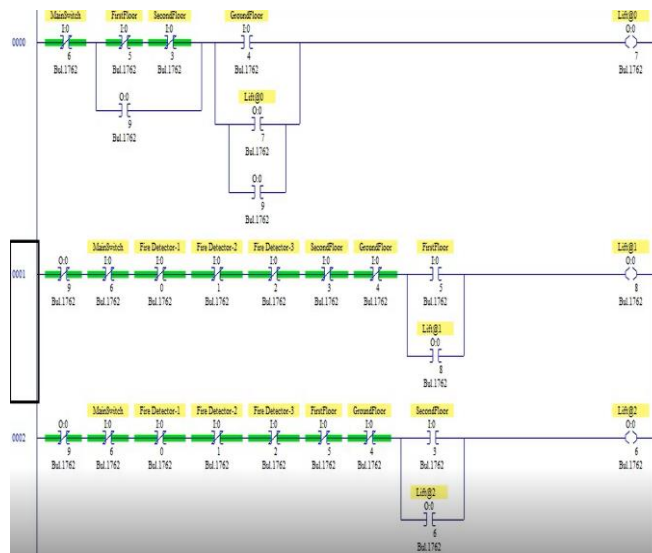

Figure 4 shows the fire detection, alert, and control conditions. The water pump gets ON based on the fire detector activation. For example, the first line in the program is used to activate water pump 1 if fire detector 1 is ON. Similarly, the second and third line are used to activate water pump 2 and 3 if fire detector 2 and 3 is ON. Then the 4th and 5th line of the ladder logic is used to activate the siren and exit door at the time of fire detection.

FIGURE 4. PLC PROGRAM PART 2

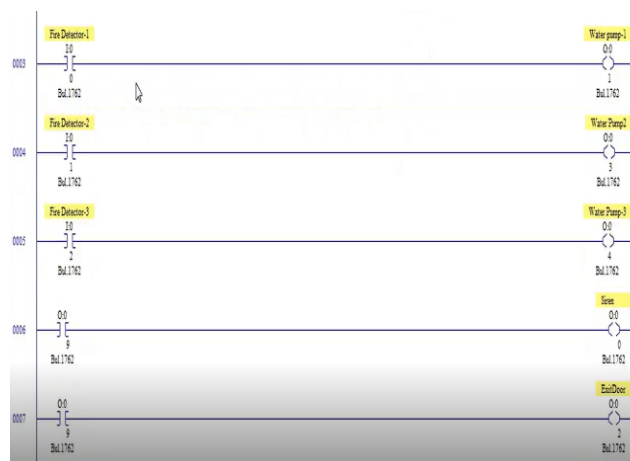

Figure 5 shows the memory allocation for detecting any one of the sensor activations. If anyone sensor is activated the memory is activated. This memory allocation is used to reduce the usage of more memories in the program.

FIGURE 5. PLC PROGRAM PART 3



### Result and Discussion

The lift operating condition is checked by pressing different buttons. The button used to operate the lift is the push button. First, the zero button is pressed, its simulation result shows in figure 6 and it clears that the lift comes to zero and it is indicated by the green color. Then the lift is not on the 1st and 2nd floor and it is also indicated by not highlighting the output in green.

FIGURE 6. SIMULATION OF LIFT BY PRESSING ZERO PUSH BUTTON AT NO FIRE CONDITION

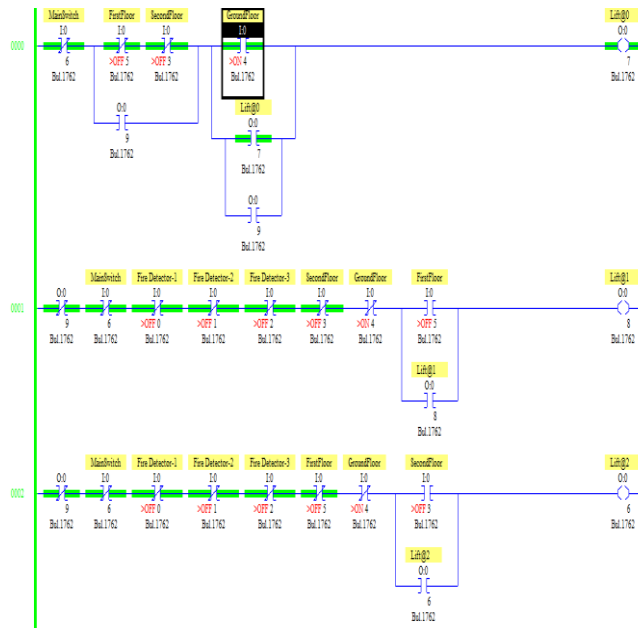

Next, the zero button is released, its simulation result shows in figure 7 and it clears that the lift will be at zero even after the button is released. It shows that the push button is working correctly. The lift is correctly on the ground floor and it is indicated by the green color. Then the lift is not on the 1st and 2nd floor and it is also indicated by not highlighting the output in green.

FIGURE 7. SIMULATION OF LIFT BY RELEASING ZERO PUSH BUTTON AT NO FIRE CONDITION

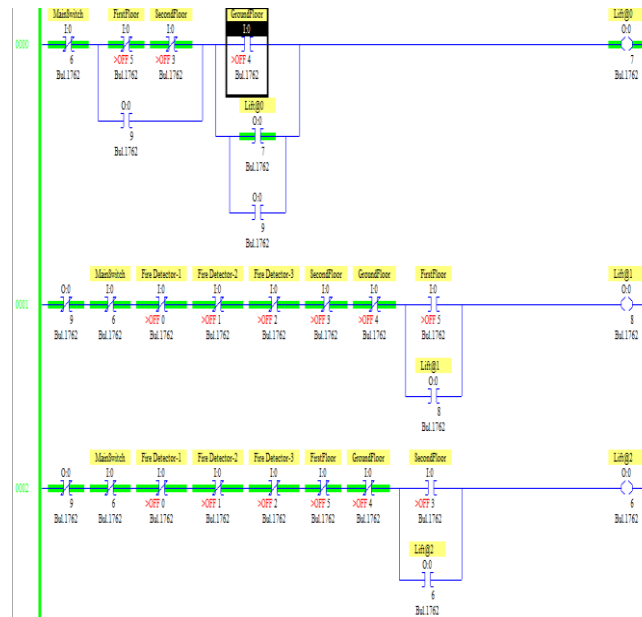

Next, the first button is pressed, its simulation result shows in figure 8 and it clears that the lift comes to the first floor and it is indicated by the green color. Then the lift is not on the ground and 2nd floor and it is also indicated by not highlighting the output in green.

FIGURE 8. SIMULATION OF LIFT BY PRESSING FIRST PUSH BUTTON AT NO FIRE CONDITION

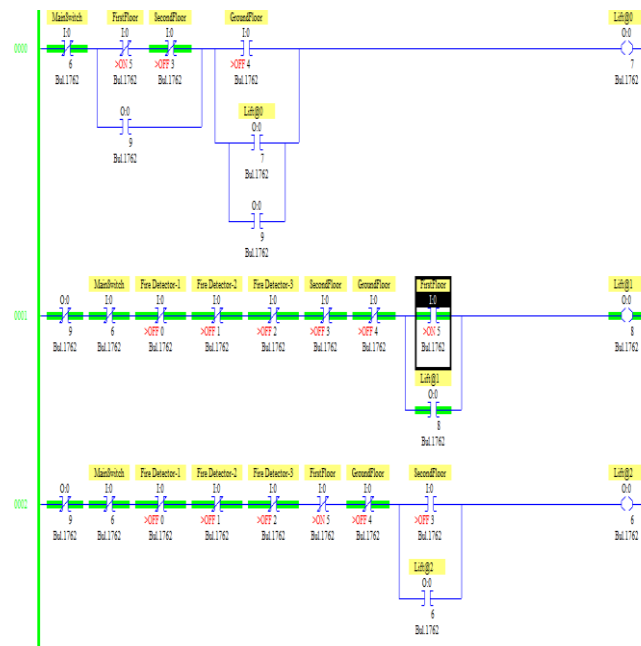

Next, the first button is released, its simulation result shows in figure 9 and it clears that the lift will be on the first floor even after the button is released. It shows that the push button is working correctly. The lift is correctly on the first floor and it is indicated by the green color. Then the lift is not on the ground and 2nd floor and it is also indicated by not highlighting the output in green.

FIGURE 9. SIMULATION OF LIFT BY RELEASING FIRST PUSH BUTTON AT NO FIRE CONDITION

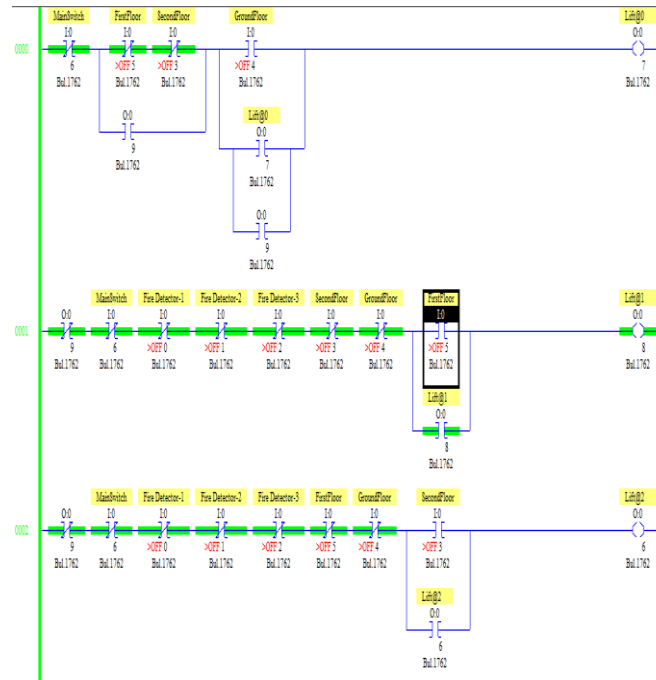

Next, the second button is pressed, its simulation result shows in figure 10 and it clears that the lift comes to the second floor and it is indicated by the green color. Then the lift is not on the ground and 1st floor and it is also indicated by not highlighting the output in green.

FIGURE 10. SIMULATION OF LIFT BY PRESSING SECOND PUSH BUTTON AT NO FIRE CONDITION

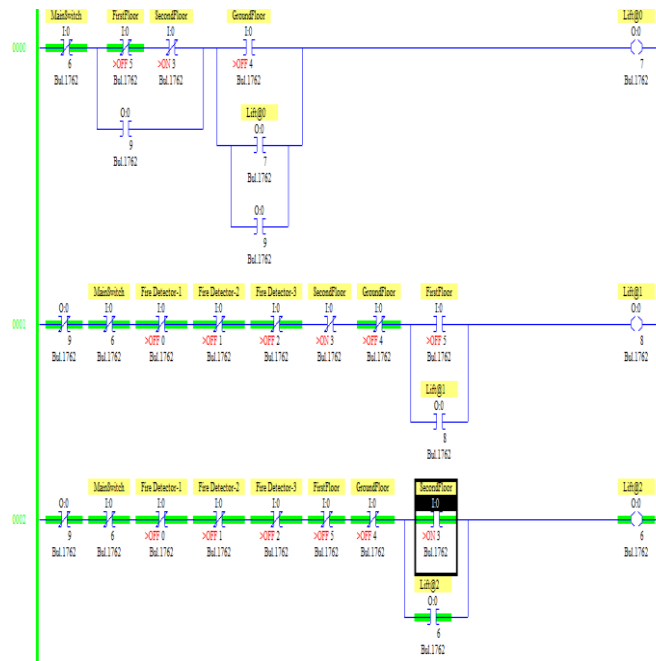

Next, the second button is released, its simulation result shows in figure 11 and it clears that the lift will be on the second floor even after the button is released. It shows that the push button is working correctly. The lift is correctly on the second floor and it is indicated by the green color. Then the lift is not on the 1st and ground floor and it is also indicated by not highlighting the output in green.

FIGURE 11. SIMULATION OF LIFT BY RELEASING SECOND PUSH BUTTON AT NO FIRE CONDITION

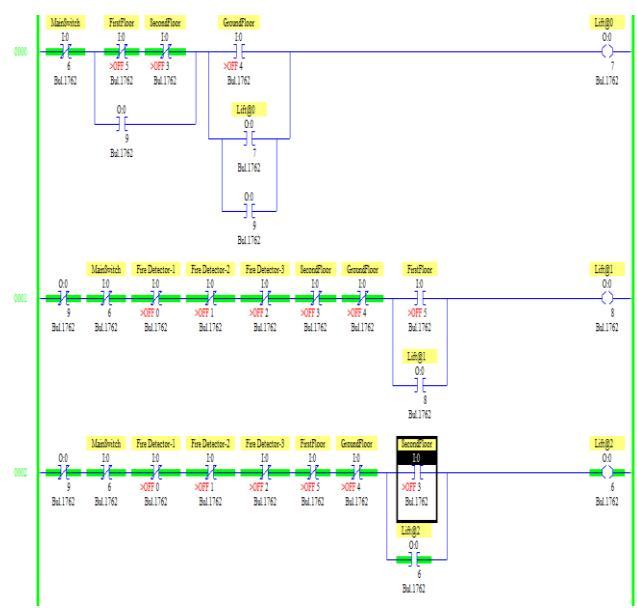

The fire is given to the simulation using the fire detector 1 switch and it is shown in figure 12. Water pump 1 is activated. Likewise, the siren, the exit door are activated. The Lift on any floor will come to the ground floor automatically. The activation of the devices like a siren, exit door, lift, and water pump 1 is indicated by green color.

FIGURE 12. SIMULATION BY GIVING FIRE AT ROOM 1

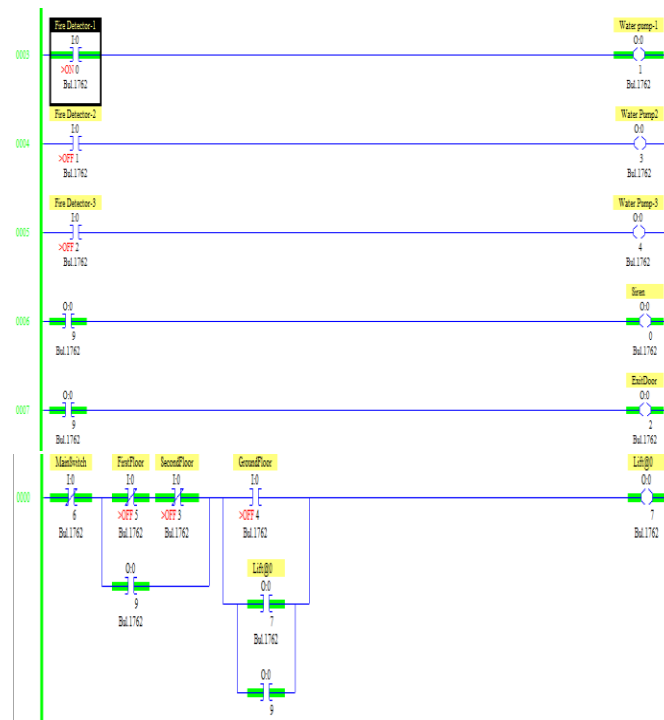

Then for check whether the lift is working at firing condition or not by pressing the buttons in the lift. The fire detector is activated by giving force to the switch. Then the lift's first-floor button is pressed. The lift will not

come to the first floor, it will remain on the ground floor and it is shown in the figure. Figure 13 shows the simulation of Lift by pressing the first push-button at fire condition in room 1.

FIGURE 13. SIMULATION OF LIFT BY PRESSING FIRST PUSH BUTTON AT FIRE CONDITION IN ROOM1

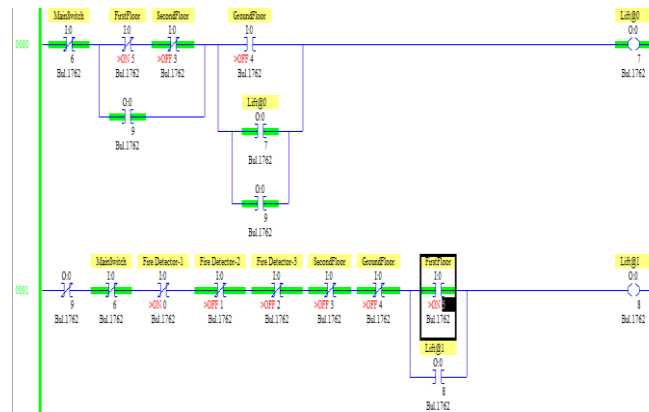

The fire is given to the simulation using the fire detector 2 switch and it is shown in figure 14. Water pump 2 is activated. Likewise, the siren, the exit door are activated. The Lift on any floor will come to the ground floor automatically. The activation of the devices like a siren, exit door, lift, and water pump 2 is indicated by green color.

FIGURE 14. SIMULATION BY GIVING FIRE AT ROOM 2

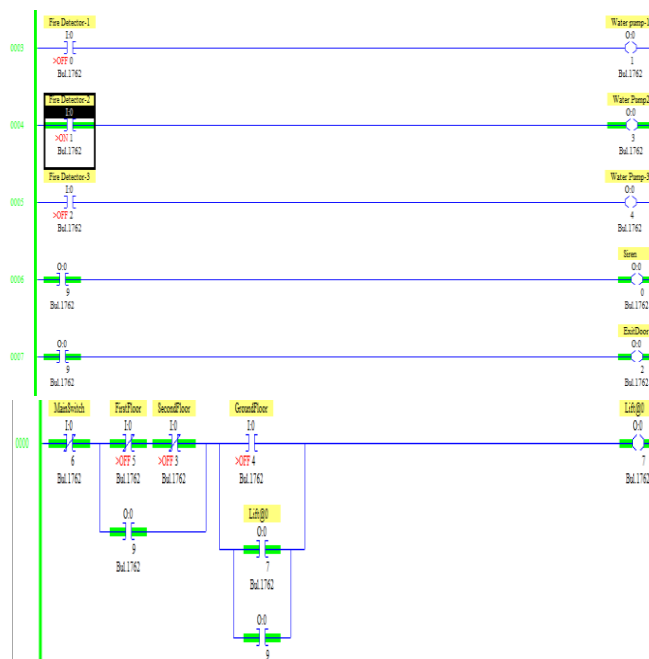

Then for check whether the lift is working at firing condition or not by pressing the buttons in the lift. The fire detector is activated by giving force to the switch. Then the lift's first-floor button is pressed. The lift will not come to the first floor, it will remain on the ground floor and it is shown in the figure. Figure 15 shows the simulation of Lift by pressing the first push-button at fire condition in room 2

FIGURE 15. SIMULATION OF LIFT BY PRESSING FIRST PUSH BUTTON AT FIRE CONDITION IN ROOM 2

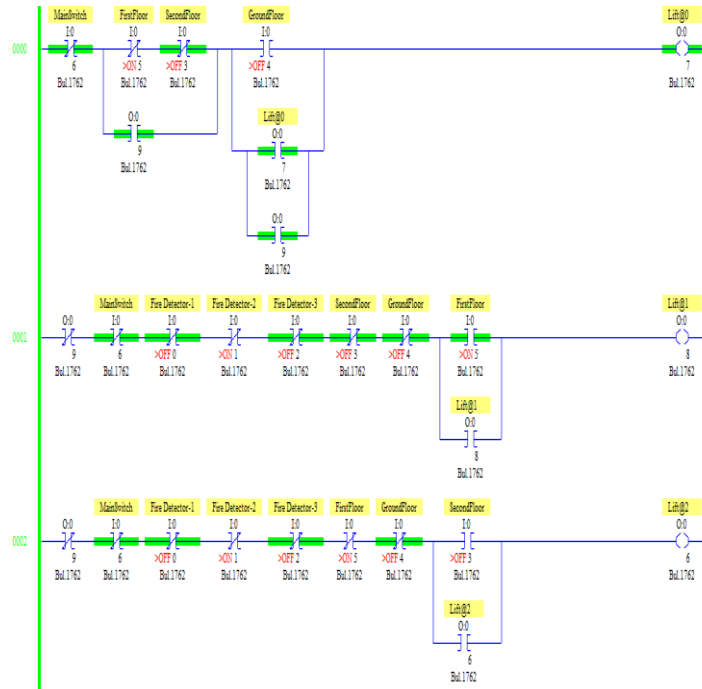

The fire is given to the simulation using the fire detector 3 switch and it is shown in figure 16. Water pump 3 is activated. Likewise, the siren, the exit door are activated. The Lift on any floor will come to the ground floor automatically. The activation of the devices like a siren, exit door, lift, and water pump 3 is indicated by green color.

FIGURE 16. SIMULATION BY GIVING FIRE AT ROOM 3

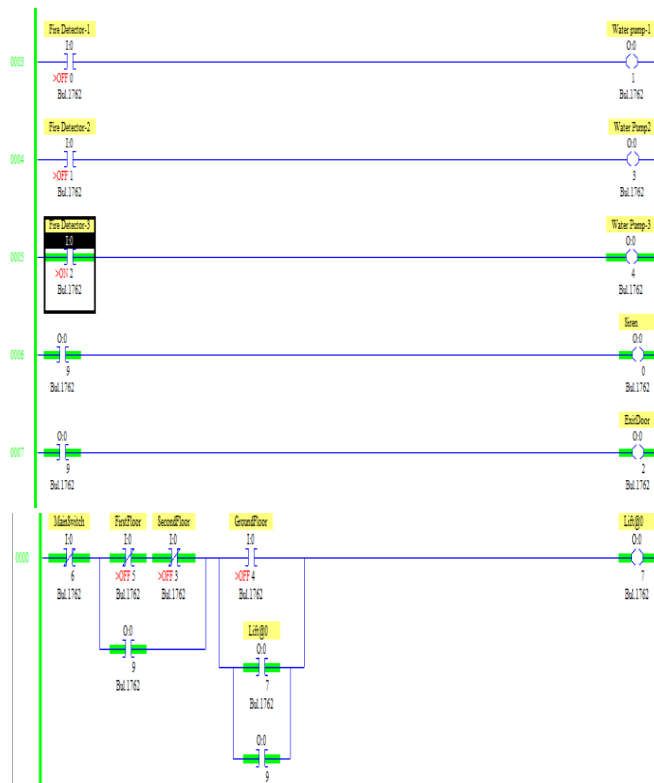

Then for check whether the lift is working at firing condition or not by pressing the buttons in the lift. The fire detector is activated by giving force to the switch. Then the lift's first-floor button is pressed. The lift will not come to the first floor, it will remain on the ground floor and it is shown in the figure. Figure 17 shows the simulation of Lift by pressing the first push-button at fire condition in room 3

FIGURE 17. SIMULATION OF LIFT BY PRESSING FIRST PUSH BUTTON AT FIRE CONDITION IN ROOM 3

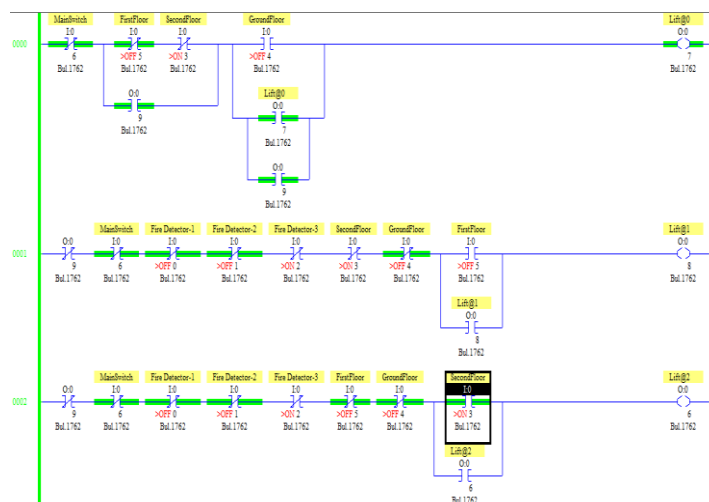

## Conclusion

The proposed system is designed for a fire alarm system. When the sensor senses the fire the valve for the water pump will get open automatically for the particular place where the fire was initiated and sensed. And when the sensor sensed the fire, the alarm will be given throughout the building. So, that the people can get an alert message to leave the building. The exit door of the building will be opened for the people to leave the building. And also, the lift is programmed to go ground floor automatically to avoid unwanted accidents while people board lifts as well as to stop people moving from one floor to another floor. This helps to reduce the loss of lives. The situation can be handled for time being with the help of water from the pump. Using this system, the level of the loss can be reduced until the fire service reaches the destination and this can system can completely take care of the situation if the accident is a small level. Implementing this system in buildings like malls, offices, schools, Hospitals, etc. will help to reduce the death due to fire accidents. In the proposed fire alarm system, the designed features may fail because of fire. Due to this panic situation, the people may fail to inform the fire service this may lead to major loss if the fire is in a wide range. These are some problems that may be encountered during the implementation of the system in the real world. In the future this system employed along with the GSM module and mobile app. The GSM module can send the intimation message about the accident even if the people failed to intimate the fire service. So, the problem will be resolved using the GSM module. The Wi-Fi module may be included in the system that may help to control the situation using the mobile itself. This will be helpful for the places like stock rooms and all. During the fire accident even If the people are not available in the stock room means also, they can turn on the water pump and alarm from the home using their mobile phone.

## References:

1. ISO/WD 7240-18, "Fire detection and fire alarm systems" Part18:Routing equipment.2002.
2. R.L. Bai. "The Analysis of Modern Building Fire Monitoring System," Automation Instrumentation, 1999, 09: 33-35.
3. T. M. Ahmed, "Smart Fire Safety System in a Building," 2018 3rd IEEE International Conference on Recent Trends in Electronics, Information & Communication Technology (RTEICT), 2018, pp. 37-40

4. H. Liu, S. Li, L. Gao and T. Wu, "About automatic fire alarm systems research," *2010 2nd IEEE International Conference on Information Management and Engineering*, 2010, pp. 419-421
5. Y. Gao, "IoT and Lightbend based Intelligent Platform for Fire Monitoring System," *2020 Second International Conference on Inventive Research in Computing Applications (ICIRCA)*, 2020, pp. 22-25
6. Sulochana Tiwari, B.N.Phadke, Praveen Patel, 2013, Design of Fire Alarm and Detection System for Hospital, *International Journal of Engineering Research & Technology (IJERT)* Volume 02, Issue 10, 2013
7. H. Liu, J. Zheng, and Y. Chen, "The Application of Multi-thread-based Embedded System in the Fire Monitor," *2009 Second International Symposium on Electronic Commerce and Security*, 2009, pp. 506-508
8. K. Gokulakrishnan, J. M. Kumar and A. M. Ashim, "Smart Fire Detection System in a Large Building Using Lora WAN," *2021 International Conference on Artificial Intelligence and Smart Systems (ICAIS)*, 2021, pp. 1111-1115
9. S. Sangamithra, S. Sakitha, R. Rajasree and T. Joby Titus, "Design and Implementation of PLC based water Curtain Nozzle Controller for Warehouse Application," *2021 5th International Conference on Computing Methodologies and Communication (ICCMC)*, 2021, pp. 715-718
10. A. Üstündağ and Ç. Gençer, "Control of automatic fire extinguishing operation for 5 forest areas with SCADA," *2021 5th International Symposium on Multidisciplinary Studies and Innovative Technologies (ISMSIT)*, 2021, pp. 535-538
11. Z. Lianyang, "Research on the Integration of High and Low Voltage Power Distribution Cabinet and Fault Monitoring Device Based on PLC and Inverter," *2020 IEEE 3rd International Conference on Information Systems and Computer Aided Education (ICISCAE)*, 2020, pp. 290-294
12. C. Wang, W. Luo and B. Xu, "The Control System Design of Concrete Mixing Station based on PLC," *2020 IEEE International Conference on Information Technology, Big Data and Artificial Intelligence (ICIBA)*, 2020, pp. 1498-1501