

Newer Approaches In Treatment Of Pain: N - Type Calcium Channel Blocker

Nityananda Sahoo (Corresponding Author)¹, Reshma Choudhury², Tapan Kumar Sahu³, Manasi Khadanga⁴, Jiten Mishra⁵, Digambar Bisoi⁶

¹Professor, Department of Pharmaceutical Chemistry, School of Pharmacy Centurion University of Technology and Management, Odisha, India-756044 Email id-nsahoo_scps05@yahoo.co.in

²Assistant Professor, Department of Pharmaceutical Analysis & Quality Assurance College of Pharmaceutical Sciences, Mohuda, Berhampur, Odisha, India-760001

³Research Scholar, Department of Pharmaceutical Chemistry, School of Pharmacy Centurion University of Technology and Management, Odisha, India-752050

⁴Assistant Professor, Department of Pharmacology Jeypore College of Pharmacy, Rondapalli. Jeypore, Odisha, India-764002

⁵Assistant Professor, Pharmaceutical Analysis & Quality Assurance Roland Institute of Pharmaceutical Sciences, Berhampur, Odisha, India-760010

⁶Assistant Professor, Department of Pharmaceutical Analysis & Quality Assurance Roland Institute of Pharmaceutical Sciences, Berhampur, Odisha, India-760010

DOI: 10.47750/pnr.2023.14.02.250

Abstract

Exceedingly particular $Ca_v2.2$ voltage-gated calcium channel (VGCC) inhibitors have developed as a unused lesson of therapeutics for the treatment of inveterate and neuropathic torment. Cone snail venoms given the primary medicate in lesson with FDA endorsement allowed in 2005 to Prialt (ω -conotoxin MVIIA, Elan) for the treatment of neuropathic torment. Since this pioneering work, major endeavors underway to create elective little atom inhibitors of $Ca_v2.2$ calcium channel have met with changed victory. This survey centers on the properties of the $Ca_v2.2$ calcium channel in numerous torment states, the action of ω -conotoxins GVIA, MVIIA and CVID, depicting their structure-activity connections and potential as leads for the plan of progressed $Ca_v2.2$ calcium channel therapeutics, and at last the improvement of little atoms for the treatment of inveterate torment.

Key words- Voltage-Gated Calcium Channel, ω -Conotoxin, Neuropathic Pain, Small Molecule Mimetics

INTRODUCTION

Calcium entry into cells mediates numerous intracellular events including muscle contraction, vesicle fusion for neurotransmitter and hormone release, gene transcription, programmed cell death, and activation of intracellular signalling cascades (e.g. [1-6]). Regulating calcium influx is critical to normal cellular function, and alterations in calcium signalling can lead to numerous pathologies. Therefore, calcium entry pathways are targets for therapeutic agents in the treatment of disorders, such as cardiovascular and epileptic dystrophies, as well as in the treatment of pain. Among the various calcium entry pathways, voltage-gated calcium channels (VGCCs) comprise a large ion channel family that allows calcium entry into cells in response to membrane depolarizations. Given their pivotal role in influencing calcium levels, it is not surprising that VGCCs are targets for several classes of therapeutic agents.

CALCIUM CHANNELS

Ten VGCC genes have been identified. These are broadly classified into high voltage-activated (requiring large membrane depolarizations to be activated) L-type Ca_v 1.1 [1S], 1.2 [1C], 1.3 [1D], and 1.4 [1F] channels, P/Q-type Ca_v 2.1 [1A] channels, N-type Ca_v 2.2 [1B] channels, and R-type Ca_v 2.3 [1E] channels, and low voltage-activated (requiring small membrane depolarizations to be activated) T-type Ca_v 3.1 [1G], Ca_v 3.2 [1H], and Ca_v 3.3 [1I] channels (see [7-11]). While each of these channel types differ in tissue expression/distribution, biophysical properties, and sensitivities to pharmacological agents, they are structurally homologous and resemble the architectures found in voltage-gated sodium and potassium channels [12, 13]. Each VGCC gene encodes a single protein consisting of four homologous domains (I-IV) each comprised of six transmembrane segments (S1-6), and intracellular N- and C-terminus (see Fig. (1); reviewed in [14]). Large intracellular linkers join the four domains

to one another, and are the sites for protein-protein interactions which help to anchor, target, or modulate the channels. Within each domain, the fourth transmembrane spanning helix (S4) contains positively charged arginine or lysine residues every three or four amino acids, and forms the voltage-sensor which moves in response to changes in membrane voltage and subsequently gates the channel [15]. The pore of the channel is lined by a re-entrant loop between the S5 and S6 membrane-spanning helices, with a glutamate residue in each of the four S5-S6 loops forming a ring of negative charge comprising the selectivity filter of the channel and permitting Ca^{2+} ions to permeate, while excluding monovalent ions [16] reviewed in [17]. Upon sustained de-polarizations, VGCCs enter a non-conducting inactivated state, which may occur in a voltage-dependent manner via a hinged-lid mechanism involving the I-II linker, as well as a calcium-dependent mechanism involving interactions of the C-terminus with the Ca^{2+} sensor calmodulin [18, 19] reviewed in [20, 21].

AUXILIARY CALCIUM CHANNEL SUBUNITS

In addition to these ten genes encoding the 1 pore forming subunits, numerous other genes encoding auxiliary subunits known to interact with VGCCs *in vivo* have also been cloned. Four genes (CACNA2D1-4) encoding the α_2/δ subunit have been cloned. Biochemical studies have shown that the protein undergoes posttranslational modifications in which the peptide is cleaved and then rejoined via disulfide bonds to form membrane spanning δ - and the highly glycosylated extracellular α_2 - domains. Four genes (CACNB1-4) encoding β - subunits have also been identified. The β - subunit interacts with the channel I-II linker, and is believed to mask an endoplasmic reticulum retention motif, in order to promote channel targeting to the extracellular membrane. Finally, eight genes (CACNG1-8) encoding γ subunits have all been found. Coexpression studies have shown that $\alpha_2/\delta, \beta, \gamma$ and proteins alter calcium current kinetics and densities, particularly with HVA calcium channels.

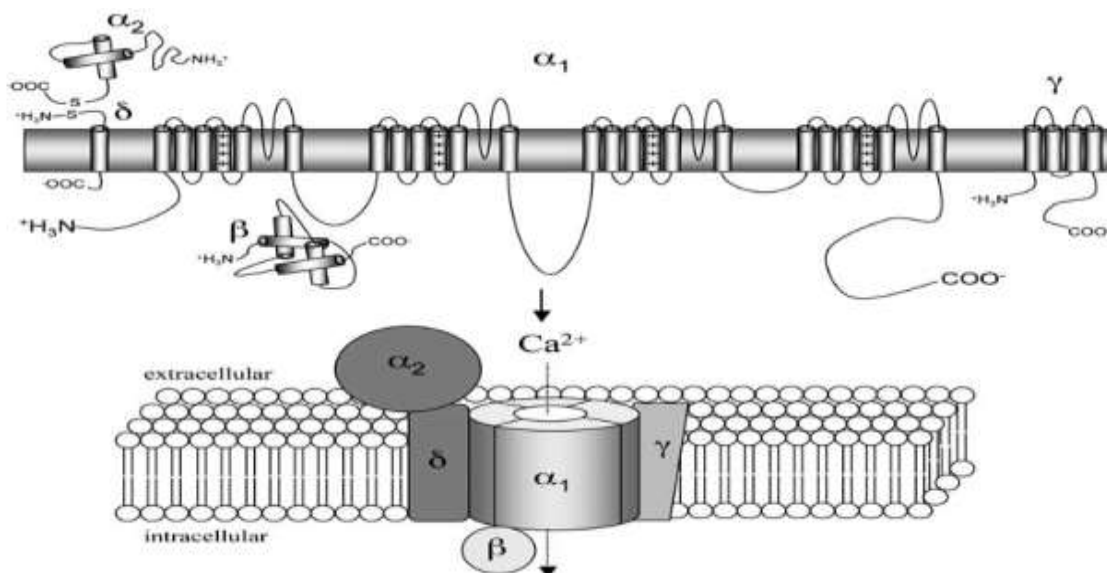

Fig. (1). Structure of VGCCs. The pore-forming 1 subunits is encoded by a single gene, and is composed of four domain, I-IV. Each do-main consists of six transmembrane helices (S1-6), with S4 serving as the voltage sensor, and the re-entrant P-loop between S5-S6 lining the pore. VGCCs associate with ancillary subunits *in vivo*. The α_2/δ subunit is encoded by a single gene which undergoes post-translational cleavage and rejoining by disulfide bonds to form membrane spanning δ - and extracellular α_2 -subunits. β -Subunits interact with the I-II linker of the channel. γ -Subunits also interact with the channel.

CALCIUM CHANNELS AS THERAPEUTIC TARGETS

Calcium channels are involved in a number of important cellular responses, including muscle contraction and neurotransmitter release. Given their diversity of physiological functions and underlying pathologies they contribute to, it is not surprising that calcium channels have emerged as an interesting therapeutic target. Of the six pharmacologically different subtypes (Table 1), the Ca_v 2.2, Ca_v 2.1 and most recently the Ca_v 3 calcium channels have emerged as biologically “validated” targets for the treatment of pain (but await commercial validation). Ca_v 2.2 channels are predominantly presynaptically located in the spinal dorsal horn region. Knockout mice lacking this channel show reduced sensitivity to certain types of pain, making this channel a therapeutic target of considerable interest.

MORPHINE AND CA_v2.2 CHANNEL

Morphine is an important therapeutic agent to treat pain, but unlike the peptide toxins or the organic blockers described above, it does not directly act on the Ca_v2.2 calcium channel itself, Fig. (2). Rather, morphine binds to μ-opioid receptors to activate a G-protein signaling cascade. Activated G_{βγ} translocates via the membrane and binds to the Ca_v2.2 calcium channel, causing massive G-protein-dependent inhibition of calcium current and hence neurotransmitter release by reducing the ability of DRG neurons to propagate pain signals. This inhibition of the Ca_v2.2 calcium channel contributes to morphine analgesia and uncoupling of the opioid receptor and G-protein signaling may underlie morphine tolerance development. Intrathecal administration of GVIA, MVIIA and CVID is effective in attenuating neuropathic pain in rats, with GVIA being about three to four times more potent than MVIIA and CVID and approximately 40-fold more potent than morphine. Importantly, inhibition of Ca_v2.2 channels with MVIIA produces substantial pain relief in otherwise treatment-refractory

patients, and unlike opioid pain management, MVIIA does not develop tolerance or produce addiction. Ca_v2.2 channel antagonists alone show analgesic effect and in combination with μ-opioids. Interestingly, several studies have reported synergistic effects between ω-conotoxins (Ziconotide or AM336) and morphine when administered IT. However, simultaneous administration of morphine and ω-conotoxin did not prevent the development of morphine tolerance. Importantly, this tolerance development did not result in cross-tolerance to MVIIA and instead there was an upregulation of ω-conotoxin binding sites (Ca_v2.2 channel) in the brain after chronic morphine exposure. Further investigation into the extent of this synergistic effect in the clinic would enable the use of lower doses of Cav 2.2 antagonists and potentially limit toxic side effects associated with IT administration of ω-conotoxins.

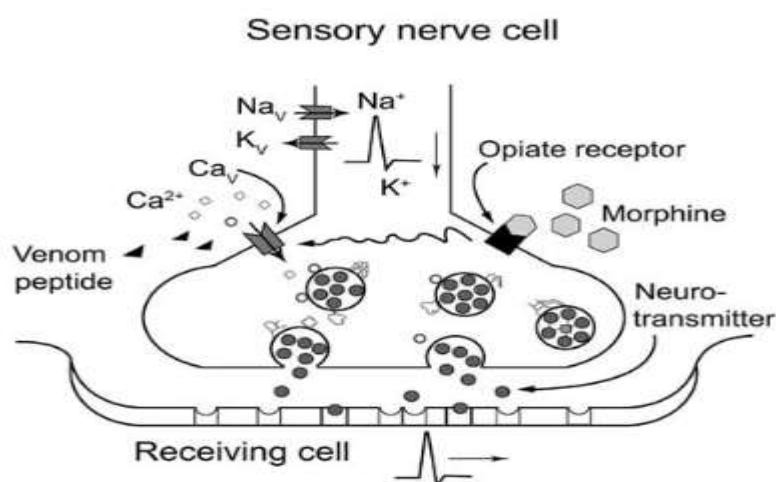

Fig. (2). Schematic figure of the presynaptic nerve terminal. Calcium influx through a Ca_v2.2 channel causes neurotransmitter release and propagation of the pain message. The propagation of the action potential and thereby the influx of calcium can be blocked by venom (e.g. Ziconotide or AM336). Activation of the opioid receptor leads to inhibition of the N-type Cav channel via G-protein coupled receptor by changing channel gating and by altering ion permeation (Adapted from Schroeder and Lewis).

PEPTIDE INHIBITORS OF CA_v2.2 CALCIUM CHANNEL

While auxiliary subunits can affect pharmacology of the channel, most blockers are targeted towards the Ca_v2.2 pore forming subunit itself. These include inorganic ions, small peptide blockers, or small organic molecules. Although inorganic ions (such as multivalent metal ions) are potent inhibitors of N-type channels (reviewed in [11]), they also block many other types of ion channels and are not clinically useful. Ca_v2.2 channels are potently inhibited by several peptides isolated from venoms from fish-hunting cone snails *Conus* spp., including GVIA, MVIIA and CVID, Fig. (3), although at higher concentrations these peptides can block multiple channel subtypes. With MVIIA, a selective ω-conotoxin Ca_v2.2 inhibitor, being approved by the FDA for pain management of neuropathic pain, the therapeutic potential of the use of ω-conotoxins selective for the Ca_v2.2 in pain management has now been established confirming the role of Ca_v2.2 channel in pain transmission.

Calcium channel	α_1 subunit	Ca ²⁺ current	Peptide antagonist
Ca _v 1.1–1.4	$\alpha_{1S,C,D,F}$	L	calciseptine, ω -agatoxin IIIA (α_{1C})
Ca _v 2.1	α_{1A}	P/Q	ω -agatoxin, MVIIIC
Ca _v 2.2	α_{1B}	N	ω -GVIA, ω -MVIIA, ω -CVID
Ca _v 2.3	α_{1E}	R	SNX-482
Ca _v 3.1–3.3	$\alpha_{1G,H,I}$	T	Kurtoxin (α_{1G})

Table1. Mammalian Ca_v Channels and Selected Peptide Inhibitors

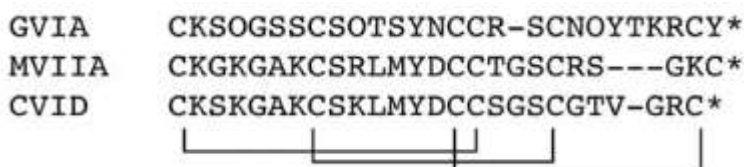

Fig. (3). Sequences and disulfide arrangement for ω -conotoxins GVIA, MVIIA and CVID

(i) **GVIA**- ω -Conotoxin GVIA, isolated from *Conus geographus*, irreversibly blocks Cav2.2 channels in the nanomolar range. The peptide has greater potency in vivo than the structurally related peptides MVIIA and CVID. GVIA is three to four times more potent than CVID and MVIIA and approximately 40-fold more potent than morphine when intrathecally administered for the attenuation of neuropathic pain in rats. However, due to its irreversible inhibition of the Cav2.2 channel it is expected to be difficult to a safe stable dosing in a clinical setting.

(ii) **MVIIA**- MVIIA from *C. magus*, also potently blocks N-type VGCCs. A synthetic version (Ziconotide, or Prialt™) of MVIIA was subsequently developed as an intrathecal agent for the management of severe pain in humans. As a result of these efforts, MVIIA was recently approved for the management of severe pain in the USA and Europe. Unfortunately, it has side effects (presumably CNS and/or spinal) despite being a highly selective N-type blocker. MVIIA produces significant pain relief in treatment refractory patients confirming the role of Cav2.2 in pain pathways. Unlike morphine, development of tolerance and addiction are not reported to develop with long term use of MVIIA.

(iii) **CVID**- More recently, CVID from *C. catus* was isolated and has since been shown to be the most selective of all known peptide blockers for Cav2.2 channels, although it is less potent than GVIA. CVID is currently in clinical trials under the name of AM336. Among the ω -conotoxins mentioned here, CVID shows a 6-orders of magnitude selectivity for the Cav2.2 over the Cav2.1 in binding studies. The peptide also has the largest therapeutic margin of the three peptides in animals and it is anticipated that CVID will produce less side effects than MVIIA in the clinic.

STRUCTURE ACTIVITY RELATIONSHIP OF ω - CONOTOXINS AT CA_v2.2

Structure-activity relationship studies of GVIA, MVIIA and CVID have revealed a number of residues being important for binding to Cav2.2 channel. This has mainly been achieved through alanine scans and other residue replacements. All these studies have unequivocally identified a conserved Tyr13 as the key binding determinant for ω -conotoxin interaction with Cav2.2. A number of additional residues, not always conserved across the ω -conotoxins, have also been shown to affect ω -conotoxin affinity. For GVIA, these residues include Lys2, Arg17, Tyr22 and Lys24, while in MVIIA these residues are Lys2, Arg10, Leu11 and Arg21. An alanine-scan has not been conducted on CVID, but instead residues have been replaced systematically with residues of similar character (e.g. Arg to Lys re- placements) or with residues believed to introduce a disruption in the binding such as Gly to Tyr replacement (Lewis et al., unpublished results). These replacement studies have

shown that like GVIA and MVIIA, residues residing in loop 2 of CVID including Lys10, Leu11 and Tyr13 are the most important for interaction with the Cav2.2 channel. In depth structure-activity analysis confirmed that the loss of activity observed when replacing Lys2 with Ala is due to a loss of a structural stabilizing interaction and Lys2 should therefore not be included in the ω -conotoxin pharmacophore. Pharmacophores for GVIA and MVIIA have been generated by grafting these structure-activity relationships onto their NMR solution structures to help guide the rational development of a novel Cav2.2 channel inhibitors, Fig. (4 A,B). Early ω -conotoxin pharmacophores included Lys2 in loop 1 as a major binding determinant. However, results from our laboratory suggest that Lys2 in CVID forms a stabilizing

interaction with Asp14 in loop 2 and is thus likely to contribute to Tyr13 stabilization. Thus an indirect effect of Lys2 on ω -conotoxin affinity cannot be excluded. Removing Lys2 produces a much more compact ω -conotoxin pharmacophore. Based on results from CVID structure-activity studies this pharmacophore contains only three residues in loop 2, Lys10, Leu11 and Tyr13, Fig. (4C). The structural effects of Lys2 highlight the need to distinguish residues involved in direct interaction with the receptor from those that play a structural or mixed role before embarking on pharmacophore-based design of mimetics. Using these minimal pharmacophores, small molecule designed to block the $Ca_v2.2$ channel have been synthesized, although the potencies of these mimetics presently fall well short of the native ω -conotoxins.

ω -CONOTOXIN INTERACTION WITH $Ca_v2.2$ CHANNEL

Biochemical and molecular biological studies have shown that the conotoxins interact with domain III of the calcium channel, Fig. (5) although other residues in the channel may be important. This binding reduces calcium influx through the channels presumably by occluding the pore. Recently, a novel peptide toxin from the spider *Ornithoctonus huwena* has also been shown to block $Ca_v2.2$ channels with similar affinity to ω -conotoxin GVIA, but in a $Ca_v2.2$ isoform specific manner.

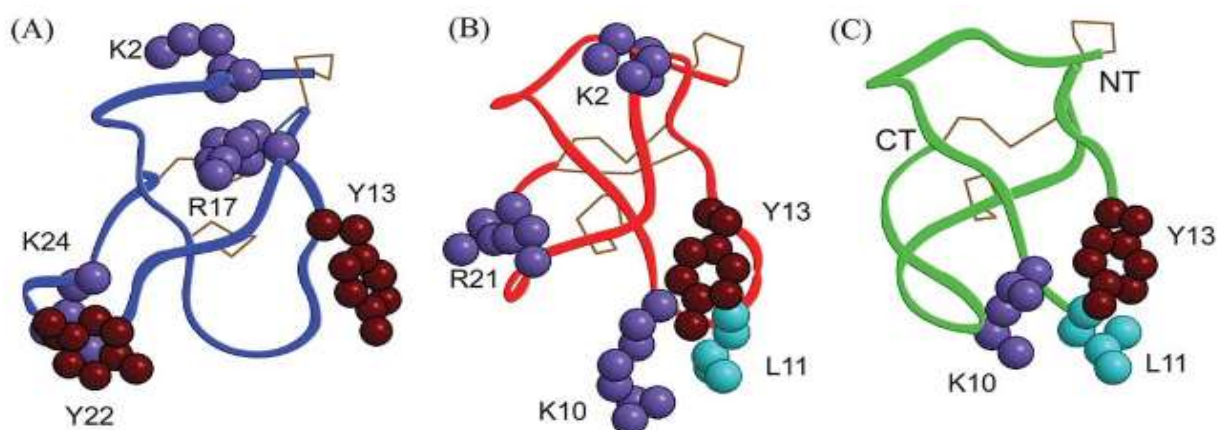

Fig. (4). ω -Conotoxin pharmacophores highlighting residues believed to be important for binding to the $Ca_v2.2$ (A) GVIA (blue) (PDB-ID; 1TTL) showing residue Lys2, Tyr13, Arg17, Tyr22 and Lys24. (B) MVIIA (red) (PDB-ID; 1TTK) displaying residues Lys2, Arg10, Leu11,

Tyr13 and Arg21 and (C) CVID (green) [71] with residues Lys10, Leu11 and Tyr13. Backbone ribbon with the disulfide bonds in orange.

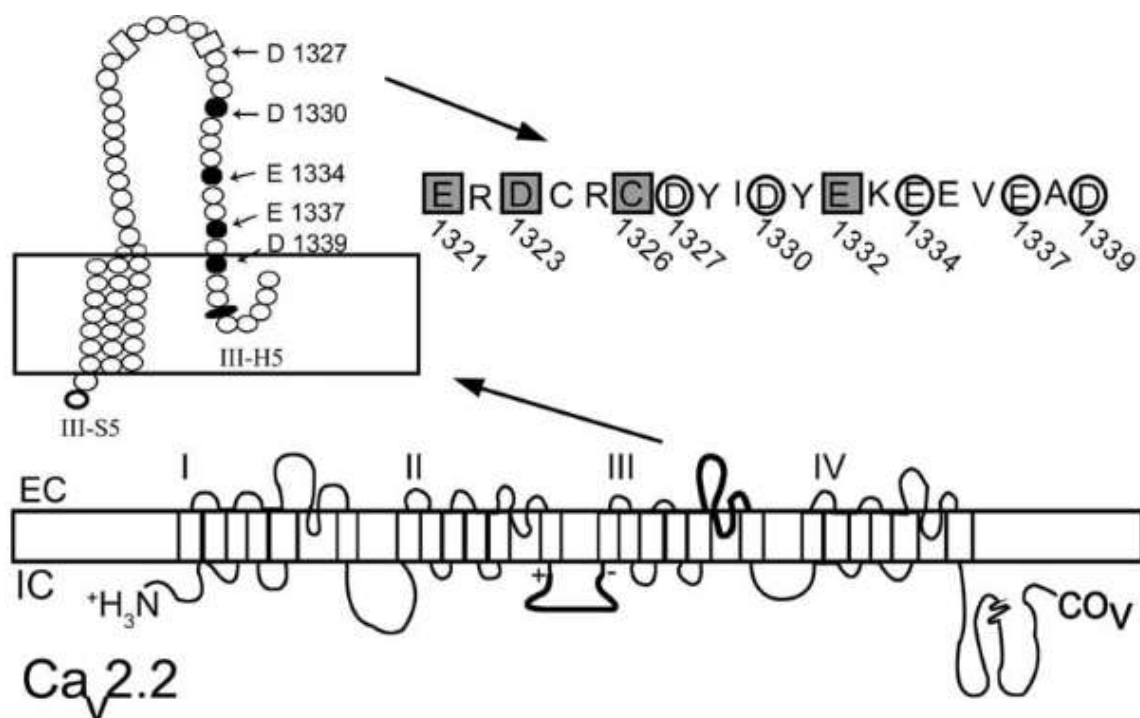

Fig. (5). Potential ω -conotoxin binding interactions with $\text{Ca}_v2.2$ channel. Proposed topology of the N-type VGCC α_{1B} subunit indicating the putative EF-hand motif (thick line, top) and the intracellular loop between domain II-III identified to cause change in GVIA and MVIIA binding to the channel (thick line bottom). Amino acids previously identified as important for GVIA block of the N-type VGCC (black circles) and proposed EF-hand motif (grey squares). Amino acid sequence of the $\text{Ca}_v2.2$ (α_{1B}) domain III S5-H5 region indicated including Gly1326 (top right).

SMALL ORGANIC MOLECULES TARGETING THE $\text{Ca}_v2.2$ CALCIUM CHANNEL

Several small organic compounds that block $\text{Ca}_v2.2$ channels have been identified, Fig. (6). For example, molecules with long alkyl chains, such as farnesol, may serve as endogenous ligands for $\text{Ca}_v2.2$ channels. They block $\text{Ca}_v2.2$ channels with high affinity/selectivity by blocking the open channel and by promoting voltage-dependent inactivation of the channels. Alkyl chains with amine groups at the terminus enhance block. $\text{Ca}_v2.2$ channels are also blocked with high affinity by novel benzyloxyaniline compounds, as well as by benzothiazole derivative mimetics of ω -conotoxin GVIA. Novel scaffolds have been synthesized and shown to be efficacious in animal models of pain including L-cysteine based compounds and aminopiperidine derivatives. Several dihydropyridines- thought of as classical Ca_v1 -family member blockers have been reported to block $\text{Ca}_v2.2$ channels with high affinity. For example, cilnidipine and pranidipine both block N- and L-type currents in vivo, with possible antinociceptive effects. Similarly, classical blockers of Ca_v1 that belong to the benzothiazepine family also inhibit $\text{Ca}_v2.2$ channels. For example, tetrandrine shows block of N-type currents in chromaffin cells in a use-dependent manner. There are a number of other compounds that block calcium currents through $\text{Ca}_v2.2$ channels, albeit non-selectively, such as gabapentin (1-(aminomethyl) cyclohexanecarboxylic acid; NeurontinTM). Its precise mode of action is unknown, but it is now established that this compound interacts with the α_2/δ subunit of the channel complex to somehow reduce calcium entry via N-type channels, thus culminating in analgesia in humans. Menzler and co-workers based their rational design on residues Arg10, Leu11 and Tyr13 as they present in MVIIA and used the dendroid approach to identify small N-type VGCC inhibitors, Fig. (7A). The dendroid approach was appealing from a drug lead perspective as the high degree of flexibility would allow for the side chain functional groups to find the preferred conformation for receptor binding. Menzler and co-workers found that molecules presenting Arg10, Leu11 and Tyr13 sidechain mimics (benzamido group, isopentyl and para-substituted phenol, respectively) produced compounds with increased affinity and decreased backbone flexibility. Unfortunately, the most active dendroid molecules did not select between the L-type VGCC and the N-type VGCC. A type-III mimetic approach used by Baell and co-workers has also generated interesting small molecules targeting the $\text{Ca}_v2.2$ channel using rational design. The type III mimetics, Fig. (7 B) were developed based on a two-point binding model including Lys2 and Tyr13 plus Arg17. One of these was found to be active at $\sim 70 \mu\text{M}$ in a N-type functional assay using vas deferens. However, no ω -conotoxin displacement studies were carried out, and therefore the specificity and site of interaction is unclear. Finally, novel organic scaffolds have been developed by biotechnology companies such as NeuroMed Technologies

Incorporated, which show high affinity and selectivity for Ca_v2.2 calcium channels in a use-dependent manner, and which are efficacious in several animal models of pain.

RATIONAL DESIGN OF SMALL PEPTIDIC MOLECULES TARGETING

THE CA_v2.2 CHANNEL

One group has used a rational approach to lead discovery of Ca_v2.2 channel peptidic inhibitors, basing their design on functional groups believed to contribute to GVIA binding to the N-type VGCC, including Lys2 and Tyr13. Pallaghy and co-workers utilized the contryphan scaffold, Fig. (8A) onto which the GVIA side chains Lys2, Tyr13 and Asn 14 were attached. The GVIA analog based on the 'contryphan scaffold' was inactive up to 100 μM in an N-type VGCC functional vas deferens assay and did not displace ¹²⁵I-GVIA at 1 mM in a rat brain synaptosome binding experiment. The ω-conotoxin pharmacophore based on structure-activity relationship data from CVID was used in combination with a vector-based approach to identify a scaffold to anchor the active side chains onto. The result was a head-to-tail cyclic pentapeptide backbone including one or more D-amino acid residues, Fig. (8B).

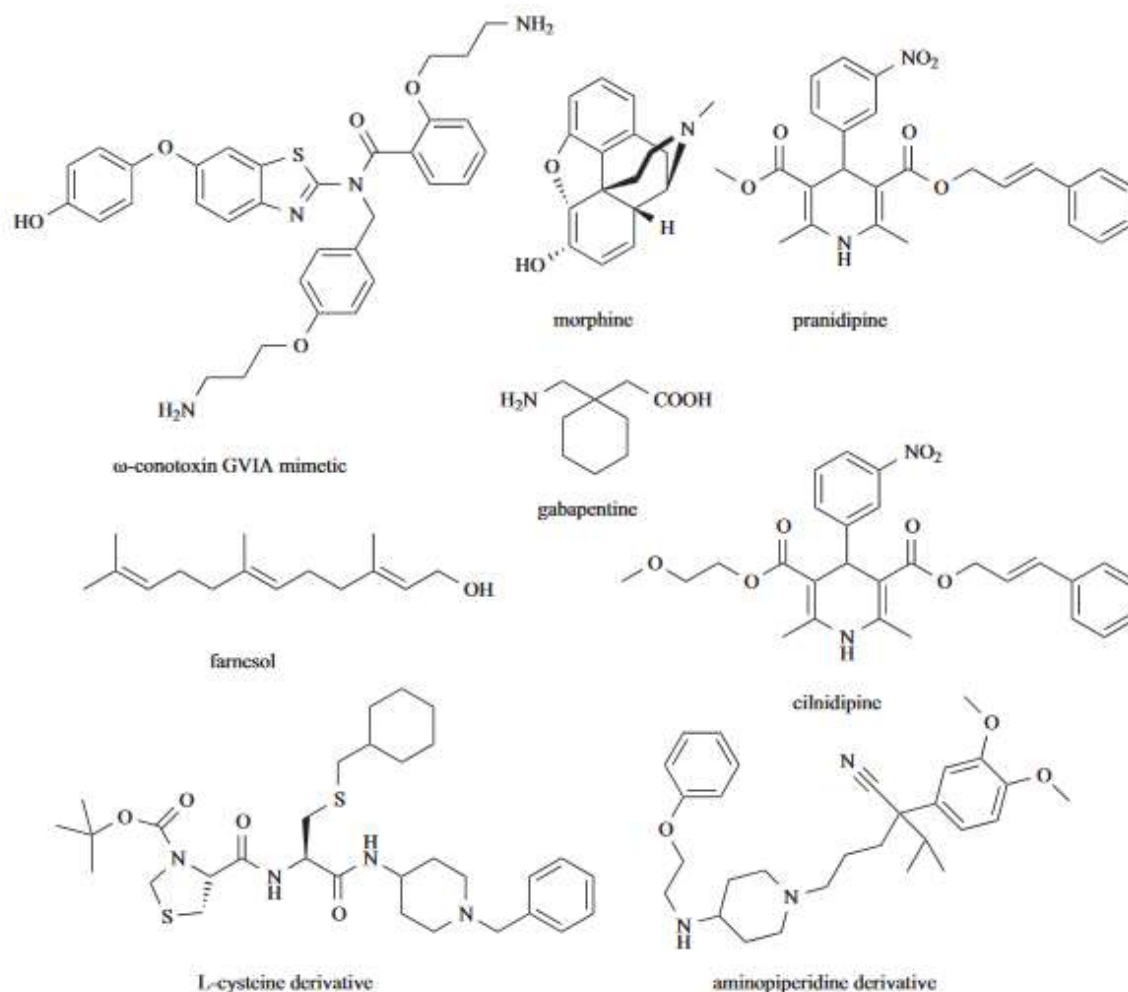

Fig. (6). Structures of some important small organic Ca_v2.2 channel blockers

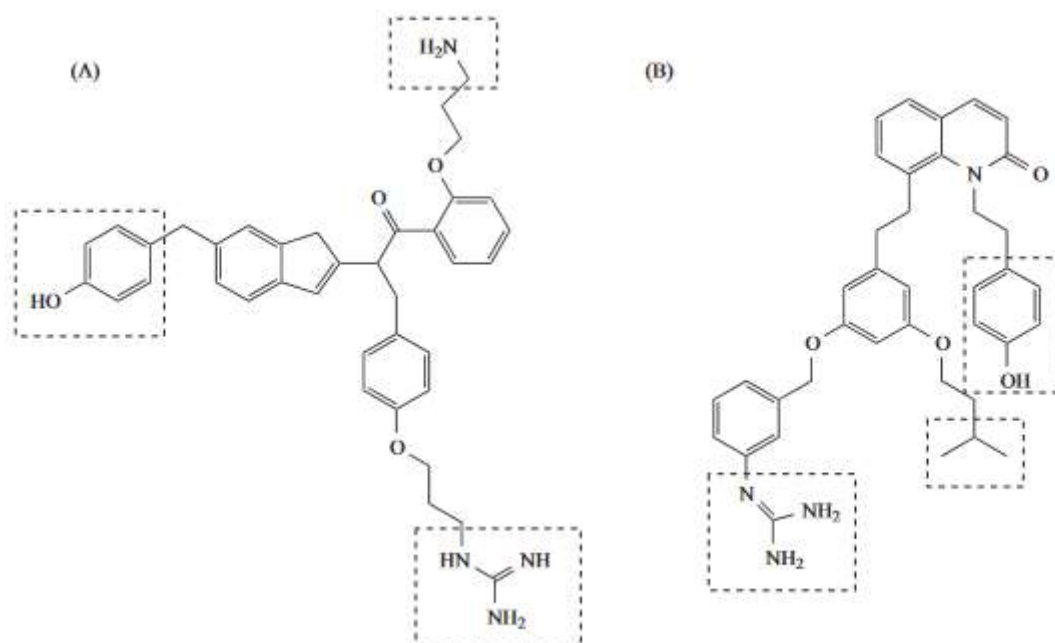

Fig. (7). Small organic $\text{Ca}_v2.2$ inhibitors develop using rational design. (A) Type-III mimetic. Dashed boxes indicate the three functional groups included to mimic the active residues Lys2, Tyr13 and Arg17 derived from GVIA. (B) Dendroid approach. Dashed boxes represent functional moieties included from SAR on MVIIA, Arg10, Leu11 and Tyr13. Appropriate references are found in the main text.

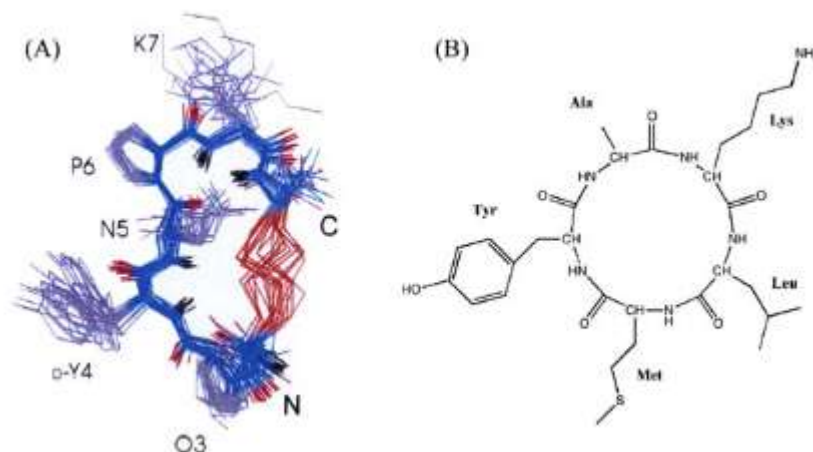

Fig. (8). (A) Superimposition of the 20 lowest energy solution structures of YNK-Contryphan R (hydrogens omitted), including residues Lys2, Tyr13 and Asn14 from the GVIA pharmacophore. C and N indicate, C- and N-terminal, respectively, connected via a disulfide bond. O3-hydroxyproline (PDB-ID; 1D7T). (B) Schematic figure of cyclic pentapeptide comprising Lys10, Leu11, Met12 and Tyr13 from the CVID derived pharmacophore, including an Ala residue to allow for head-to-tail cyclization.

The most active of the cyclic pentapeptides showed dose-dependent inhibition of ^{125}I -GVIA at the $\text{Ca}_v2.2$ channel in rat brain (IC_{50} values 40–60 μM). Whilst these small molecules still only display modest activity, they were found to retain selectivity for the $\text{Ca}_v2.2$ channel over the undesired $\text{Ca}_v2.1$ channel and are consequently promising candidates for further development in the search for novel therapies for the treatment of pain. There has never been a more critical need for novel therapeutics for pain management with a number of Cox-2 inhibitors withdrawn from the market. While Prialat, the first FDA approved conotoxin, displays some undesired side effects, the more N-type selective ω -conotoxin AM336 has a larger therapeutic window, confirming that $\text{Ca}_v2.2$ channel inhibitors can be developed with fewer side effects. Given this progress, medicinal chemists are now in a strong position to design novel small molecule inhibitors of N-type calcium channels for the treatment of intractable pain. Ideally, such inhibitors would target rapidly firing or depolarized nerves (use dependent or functional selectivity) as well as selectivity for those N-type currents in ascending pathways that underly chronic pain states.

CONCLUSION

The ω -conotoxin pharmacophore based on structure-activity relationship data from CVID was used in combination with a vector-based approach to identify a scaffold to anchor the active side chains onto. The result was a head-to-tail cyclic pentapeptide backbone including one or more D-amino acid residues, Fig. (8B). The most active of the cyclic pentapeptides showed dose-dependent inhibition of ^{125}I -GVIA at the $\text{Ca}_v2.2$ channel in rat brain (IC_{50} values 40–60 μM). Whilst these small molecules still only display modest activity, they were found to retain selectivity for the $\text{Ca}_v2.2$ channel over the undesired $\text{Ca}_v2.1$ channel and are consequently promising candidates for further development in the search for novel therapies for the treatment of pain. There has never been a more critical need for novel therapeutics for pain management with a number of Cox-2 inhibitors withdrawn from the market. While Prialat, the first FDA approved conotoxin, displays some undesired side effects, the more N-type selective ω -conotoxin AM336 has a larger therapeutic window, confirming that $\text{Ca}_v2.2$ channel inhibitors can be developed with fewer side effects. Given this progress, medicinal chemists are now in a strong position to design novel small molecule inhibitors of N-type calcium channels for the treatment of intractable pain. Ideally, such inhibitors would target rapidly firing or depolarized nerves (use dependent or functional selectivity) as well as selectivity for those N-type currents in ascending pathways that underly chronic pain states.

REFERENCES

- [1] Tsien, R.W.; Lipscombe, D.; Madison, D.V.; Bley, K.R.; Fox, A.P. *Trends. Neurosci.*, 1988, 11,431.
- [2] Wheeler, D.B.; Randall, A.; Tsien, R.W. *Science*, 1994, 264, 107.
- [3] McCleskey, E.W. *Curr. Opin. Neurobiol.*, 1994, 4, 304.
- [4] Dunlap, K.; Luebke, J.I.; Turner, T.J. *Trends. Neurosci.*, 1995, 18,89.
- [5] Dolmetsch, R.E.; Pajvani, U.; Fife, K.; Spotts, J.M.; Greenberg, M.E. *Science*, 2001, 280, 69.
- [6] Dolmetsch, R.E. *Sci. STKE.*, 2003, E4.
- [7] Bean, B.P. *Annu. Rev. Physiol.*, 1989, 51, 367.
- [8] Hess, P. *Annu. Rev. Neurosci.*, 1990, 13, 337.
- [9] Ertel, E.A.; Campbell, K.P.; Harpold, M.M.; Hofmann, F.; Mori, Y.; Perez-Reyes, E.; Schwartz, A.; Snutch, T.P.; Tanabe, T.; Birnbaumer, L.; Tsien, R.W.; Catterall, W.A. *Neuron*, 2000, 25, 533.
- [10] Tsien, R.W.; Ellinor, P.T.; Horne, W.A. *Trends. Pharmacol. Sci.*, 1991, 12, 349.
- [11] Doering, C.J.; Zamponi, G.W. *J. Bioenerg. Biomembr.*, 2003, 35,491.
- [12] Doyle, D.A.; Morais, C.J.; Pfuetzner, R.A.; Kuo, A.; Gulbis, J.M.; Cohen, S.L.; Chait, B.T.; MacKinnon, R. *Science*, 1998, 280, 69.
- [13] Jiang, Y.; Lee, A.; Chen, J.; Ruta, V.; Cadene, M.; Chait, B.T.; MacKinnon, R. *Nature*, 2003, 423, 33.
- [14] Catterall, W.A. *Annu. Rev. Cell. Dev. Biol.*, 2000, 16, 521.
- [15] MacKinnon, R. *Science*, 2004, 306, 1304.
- [16] Lipkind, G.M.; Fozzard, H.A. *Biochemistry*, 2001, 40, 6786.
- [17] Heinemann, S.H.; Schleif, T.; Mori, Y.; Imoto, K. *Braz. J. Med. Biol. Res.*, 1994, 27, 2781.
- [18] Stotz, S.C.; Hamid, J.; Spaetgens, R.L.; Jarvis, S.E.; Zamponi, G.W. *J. Biol. Chem.*, 2000, 275, 24575.
- [19] Liang, H.; DeMaria, C.D.; Erickson, M.G.; Mori, M.X.; Alseikhan, B.A.; Yue, D.T. *Neuron*, 2003, 39, 951. [20] Stotz, S.C.; Zamponi, G.W. *Trends. Neurosci.*, 2001, 24, 176.
- [21] Halling, D.B.; Aracena-Parks, P.; Hamilton, S.L. *Sci. STKE.*, 2005, re15.
- [22] Felix, R. *Receptors Channels*, 1999, 6, 351.
- [23] Klugbauer, N.; Lacinova, L.; Marais, E.; Hobom, M.; Hofmann, F.J. *Neurosci.*, 1999, 19, 684.
- [24] De Jongh, K.S.; Warner, C.; Catterall, W.A. *J. Biol. Chem.*, 1990, 265, 14738.
- [25] Jay, S.D.; Sharp, A.H.; Kahl, S.D.; Vedvick, T.S.; Harpold, M.M.; Campbell, K.P. *J. Biol. Chem.*, 1991, 266, 3287.
- [26] Richards, M.W.; Butcher, A.J.; Dolphi, A.C. *Trends. Pharmacol. Sci.*, 2004, 25, 626.
- [27] Bichet, D.; Cornet, V.; Geib, S.; Carlier, E.; Volsen, S.; Hoshi, T.; Mori, Y.; De Waard, M. *Neuron*, 2000, 25, 177.
- [28] Chu, P.J.; Robertson, H.M.; Best, P.M. *Gene*, 2001, 280, 37.
- [29] Yasuda, T.; Chen, L.; Barr, W.; McRoy, J.E.; Lewis, R.J.; Adams, D.J.; Zamponi, G.W. *Eur. J. Neurosci.*, 2004, 20, 1.
- [30] Arikath, J.; Cambell, K.P. *Curr. Opin. Neurobiol.*, 2003, 13, 298.
- [31] Augustine, G.J.; Charlton, M.P.; Smith, S.J. *Annu. Rev. Neurosci.*, 1987, 10, 633.
- [32] Miller, R.J. *Science*, 1987, 235, 46.
- [33] Westenbroek, R.E.; Hoskins, L.; Catterall, W.A. *J. Neurosci.*, 1998, 18, 6319.
- [34] Westenbroek, R.E.; Hell, J.W.; Warner, C.; Dubel, S.J.; Snutch, T.P.; Catterall, W.A. *Neuron*, 1992, 9, 1099.
- [35] Takemura, M.; Kiyama, H.; Fukui, H.; Tohyama, M.; Wada, H. *Brain Res.*, 1988, 451, 386.
- [36] Gohil, K.; Bell, J.R.; Ramachandran, J.; Miljanich, G.P. *Brain Res.*, 1994, 653, 258.
- [37] Kim, C.; Jun, K.; Lee, T.; Kim, S.S.; McEnery, M.W.; Chin, H.; Kim, H.L.; Park, J.M.; Kim, D.K.; Jun, S.J.; Kim, J.; Shin, H.S. *Mol. Cell. Neurosci.*, 2001, 18, 235.
- [38] Saegusa, H.; Kurihara, T.; Zong, S.; Kazuno, A.; Matsuda, Y.; Nonaka, T.; Han, W.; Toriyama, H.; Tanabe, T. *EMBO J.*, 2001, 20, 2349.
- [39] Herlitz, S.; Garcia, D.E.; Mackie, K.; Hille, B.; Scheuer, T.; Catterall, W.A. *Nature*, 1996, 380, 258.
- [40] Zhang, J.F.; Ellinor, P.T.; Aldrich, R.W.; Tsien, R.W. *Neuron*, 1996, 17, 991.
- [41] Zamponi, G.W.; Snutch, T.P. *Curr. Opin. Neurobiol.*, 1998, 8, 351.
- [42] Schroeder, C.I.; Lewis, R.J. *Mar. Drugs*, 2006, 4, 193.
- [43] Basbaum, A.I. *Pain*, 1995, 61, 349.
- [44] Kennedy, C.; Henderson, G. *Mol. Pharmacol.*, 1991, 40, 1000.

- [45] Kennedy, C.; Henderson, G. *Neuroscience*, 1992, 49, 937.
- [46] Tao, P.L.; Lee, C.R.; Law, P.Y.; Loh, H.H. *Naunyn Schmiedebergs Arch. Pharmacol.*, 1993, 348, 504.
- [47] Scott, D.; Wright, C.; Angus, J. *Eur. J. Pharmacol.*, 2002, 451, 279.
- [48] Jain, K.K. *Expert. Opin. Investig. Drugs*, 2000, 9, 2403.
- [49] Wang, Y.-X.; Gao, D.; Pettus, M.; Phillips, C.; Bowersox, S.S. *Pain*, 2000, 84, 271.
- [50] Brose, W.G.; Gutlove, D.P.; Luther, R.R.; Bowersox, S.S.; McGuire, D. *Clin. J. Pain.*, 1997, 13, 256.
- [51] Suh, H.W.; Song, D.K.; Choi, S., R.; Huh, S.O.; Kim, Y.H. *Brain Res.*, 1997, 767, 144.