

AUTOMATIC SOLAR TRACKING SYSTEM

Anu .G. Pillai

Assistant Professor, Kalinga University.

Email: anu.pillai@kalingauniversity.ac.in

DOI: 10.47750/pnr.2023.14.S02.222

Abstract

Solar energy, amongst a variety of sustainable energy sources, is the main energy and has quickly acquired its importance. A sun-based global positioning framework can provide generous levels of energy that make the utility of solar chargers much more efficient. The inverse proportionality of solar rays and solar-powered chargers is an explanation for their efficiency: financially, the initial cost and development components of a model for a sun-oriented global positioning framework with a sole opportunity center. The basic control circuitry relies on the NodeMcu microcontroller. The gadget is programmed such that the LDR sensor guides the DC motor in the direction the solar charger should turn, depending on the sun's rays. This positions the solar charger to capture the maximum amount of sunlight. In relation to other motors, DC motors are the simplest and smoothest motors, with high power and moderately slow speed. All exceptions can be accounted for and programmed to adjust course. 1985 saw the first production of solar-based silicon cells with 20% efficiency. But while improving the efficiency of solar chargers had compelling benefits, error-free was a great goal. Below 40% most boards float to work. To meet individual needs or buy own frameworks with appropriate results group of people need to buy different boards.

Keyword – Renewable energies, Solar panel, Microcontroller, LDR, DC motor, Single, Axis Tracker etc.

INTRODUCTION

A noisy civilization is a gold mine where the current development is taking place. Energies are used in stages to make the most of it desires and longings of population groups. Different layers of obstacles and recoil energy considered to be the deciding factor which limits the every aspects of human's life. An entity that develops in nature probably belongs to nature, the best product of the race to show the possible and available equipment e benefit in every way possible in this dangerous world. Test framework shows, broken down according to different assessments, which decisions are more desirable to accelerate the energy shortage in a very heterogeneous society like ours. Our word, it is a worthy energy saving goal. It is an achievement from the point of pollution in the world, this framework is an ecological substitute and an important resource to pursue. Whenever the spread of pollutants disturbs every corner of Life, this frame will have the ability to create a wave of Self-confidence in the stormy development of mankind. It comes from her functionality. He is most likely a pioneer in using his correlation model in other great frameworks.

RELATED WORK

The limitations of accessible assets have made today's society to switch for means to perfect the requirements. In supporting progress, the general depletion of fill by human practices was a warning of the problems of rational progress. It has led us to a hopeful way to use. It has been considered that sun is the principal energy source. Energy generated from solar is an eco-friendly advantage unlike our partners. Advances in innovation are challenging strategies to turn this energy into their own greater profit. Nuclear power, electric power, fuel power

generation, etc. Photovoltaics or CSP (Concentrated Sunlight Based Power) framework is being developed to convert sun-directed energy withdrawn from the earth into energy. Solar-based GPS beacons harness this captured solar energy through a channel of photovoltaic exhibits, which is an array platform of photovoltaic cells.

Light energy is converted into electricity by using photovoltaic cells. Unlike photoelectric effect, solar cells operate are based on the photovoltaic effect. In contrast, in photovoltaics, electrons are not transmitted, but remained on the surface of the conductor which creates the potential difference. Solar cells are made of semi-transparent silicon. This is the material most commonly involved in solar-based cells. The use of silicon in sun-directed cells has been highly effective and minimally costly.

Two kinds of clear silicone can be utilized to make daylight based cells. Aside from silicon, cadmium telluride (CdTe), copper indium gallium (di)selenide (CIGS), and so forth are utilized to foster the sun based cells. Silicon is the material of decision for use in sun oriented based follow-up frameworks, as assembling sun powered cells with other silicon materials is somewhat more costly. [2]

The best and most widely used one material, single crystal silicon, has an efficiency of about 15-20%. At elevated temperatures, the cellular material display is reduced by 10-15% of the original. [3] Polycrystalline silicon has a different structure and is cheaper than the last option, but has a band hole similar to monocrystalline silicon. It has similar band gap energy, but is less effective, so this material is used at the lowest cost. Nebulus silicon cells can operate at any temperature and the productivity of Nebulus silicon cells is relatively low than other structures of silicon.

Table 1: Categories of solar cells

| Cell Technology | Crystalline Silicon |
|-------------------------|--|
| Types | <ul style="list-style-type: none"> • Mono-crystalline silicon (c-Si) • Poly-crystalline silicon (pc-Si/ mc-Si) |
| Temperature resistivity | Lower |
| Module Efficiency | 13-19% |

Slender film solar structures of sun radiation-oriented cells are innovatively made by using CIGS, CdTe and with thin film of amorphous silicon (a-Si, TF-Si). These delicate solar-based film cells are a little more economically savvy than glass-like silicon photovoltaic cells. [4] Different elements influence sun oriented cell proficiency are temperature of the cell, effectiveness of energy transformation, most extreme power point following. . [5]

Solar cells are arranged sequentially to form a solar panel. Those PV cells are fabricated in solar panels or PV arrays to serve for photon excitation of electrons in the materials present in the solar cell. Position of sun is of important concern which decides the amount of sun rays received by the solar panel as well. Sun a preeminent and permanent source of energy is a long-lasting ocean with radiates the maximum solar energy. Solar panels receive this energy as natural energy source. Alternative methods have been developed to meet the usage this energy in proper manner. Manipulation of energy sources is encouraged given the prosperity of various applications that bring about change to conserve other resources. [7] Thus, electrical energy is extracted from these solar panels which is great use. They concentrate on the different aspects as how efficiently the solar energy can be bagged.

In order to collect the maximum energy, the sunlight must directly fall on the solar panels i.e. an orthogonal angle is made between the panel and sunlight falling on it. Mechanism, tracking controller and drive motor are the three different modules which altogether forms the solar tracking system. The precise movement of sun during the day time is followed with help of this mechanism. In order to compensate the adverse effect of the weather the device is made robust. It has two segment mechanism system namely single axis and dual axis trackers. [9]

Convenient system is considered in single axis tracking system or top of the line solution for the small capacity solar plants. It can be categorized into three different forms which generally based on the working of the axes.

- Installation of inclined shaft
- Horizontal installation of south- north axis
- Horizontal installation of east-west axis

One cardinal direction is maintained in single axis tracker tracks. Tracking configuration has single tracker system. Various arrangements are implemented amongst the above-mentioned single axis tracking system. All cultivation methods are equally effective. The angle between the sun radiation and the surface of the photovoltaic collector is synthesized and formulated. With the movement of the sun in the surrounding is tracked with the collector in order to meet expectations of capturing a greater proportion of solar radiation.

- Horizontal Single Axis Tracker (HSAT)
- Horizontal Single Axis Tracker with Tilt Module (HTSAT)
- Vertical Single Axis Tracker (VSAT)
- Tilt Single Axis Tracker (TSAT)
- Polar Aligned Single Axis Tracker (PSAT)

The axes of the system are perpendicular to each other. Ground level is considered to be the reference for one axis. Amongst them one axis is called as major axis and another one is minor axis. The horizontal and vertical movement is achieved in two axis trackers. These tracker uses two different aspects of connections namely

- Tip-Tilt Dual Axis Tracker
- Azimuthal Altitude Dual Axis Tracker

Dual axis trackers are most efficient than single axis tracker. It usually captures the maximum energy from the sun by properly tracking the its movement. Generally, there are two types of solar trackers are available which are based on the driving mechanism called as active and passive solar trackers. Active drive mechanism is defined to use DC motors as an electric motor. Passive are ones which governed by the movement of the earth or gravity.

There are two different types of solar tracker controller modules such as

- 1) Open loop control – governed by making the use of microprocessor. In this method the overall span of day is consider to analyze the movement of sun, which incorporates the determination of time and direction of sun by using the microcontroller. Geographical condition does not affect this kind of control system as such.
- 2) Closed Loop Control or Feedback Controller – light sensor is used in this system in order to compare the light intensity with stored values. Light sensor is attached to solar panel at the corners which help to detect the movement of the sun.

Horizontal single axis system of tracker is used here. Here the light sensors are used to follow the movement of sun which are very sensitive to light. Classification of this kind tracking system is called as active tracking system which is based on the concept of feedback or closed loop system. Surrounding light intensity is analyzed which unable the solar panel to move towards the high light intensity region. Hence the system in general uses weather conditions as feedback for the movement. [5]

The proposed system has appropriate control over the movement of the sun. This sun-based global positioning framework instrument is divided into two sections: single-hub tracker and double-hub tracker. [8]

For small scale solar power plants single hub can be consider as one of the most efficient frameworks or primary deployments. With three unique game plans along with single hub tracking enables relying on different tomahawks for tracking called Slanted shaft establishment, South-North hub level establishment. East-West pivot level establishment.

Single column array is setup within the tracker. The mentioned strategies with various plans that a single pivot tracker can execute. The working components of the relative diversity of competing strategies are comparable to each other. As sun points with outer layers of authority are processed and inspected, collectors are encouraged to follow the movement of the sun in order to catch the assumption that it attracts more pronounced levels of Sun-directed brilliance.] There are many other single hub tracker roads such as

- Level Single Axis Tracker (HSAT)
- Flat Single Axis Tracker with Tilted Module (HTSAT)
- Vertical Single Axis Tracker (VSAT)
- Shifted Single Axis Tracker (TSAT)
- Polar Aligned Single Axis Tracker (PSAT)

Symmetry can be seen in double pivot tracker. Ground is used to fix one of the tomahawks. This pivot point is called the essential hub and the remaining hubs are called auxiliary hubs. A tracker with two hubs moves along her two origins, plane and perpendicular. Dual pan trackers have many uses, but the most common are:

- Tip-Tilt Dual Axis Tracker
- Azimuthal Altitude Dual Axis Tracker. [10]

These kinds of solar trackers are most efficient that single pivot tracker. It usually follows the most extreme solar-based energy generation.

SYSTEM IMPLEMENTATION

Programmed Solar Tracking System is created with establishment of different bare essential, for example, sunlight-based charger which gives 12 V at the output. The system consists of a NodeMcu as MCU, an IC L293D called as engine driver, LDR sensor module, 10 r.p.m. basic DC motor, current sensor and 9 V battery. Development of proposed work is performed by using the wooden base introduced at its ground. On either side, system is attached with the iron poles in a cross-formed way associated with an empty tube-shaped bar and on another edge of the empty bar a DC motor is attached. Framework is isolated in such a manner of three-crease segments into which the circuit of the sunlight.

Fig. 1 Block Diagram of Automatic Solar Tracking System

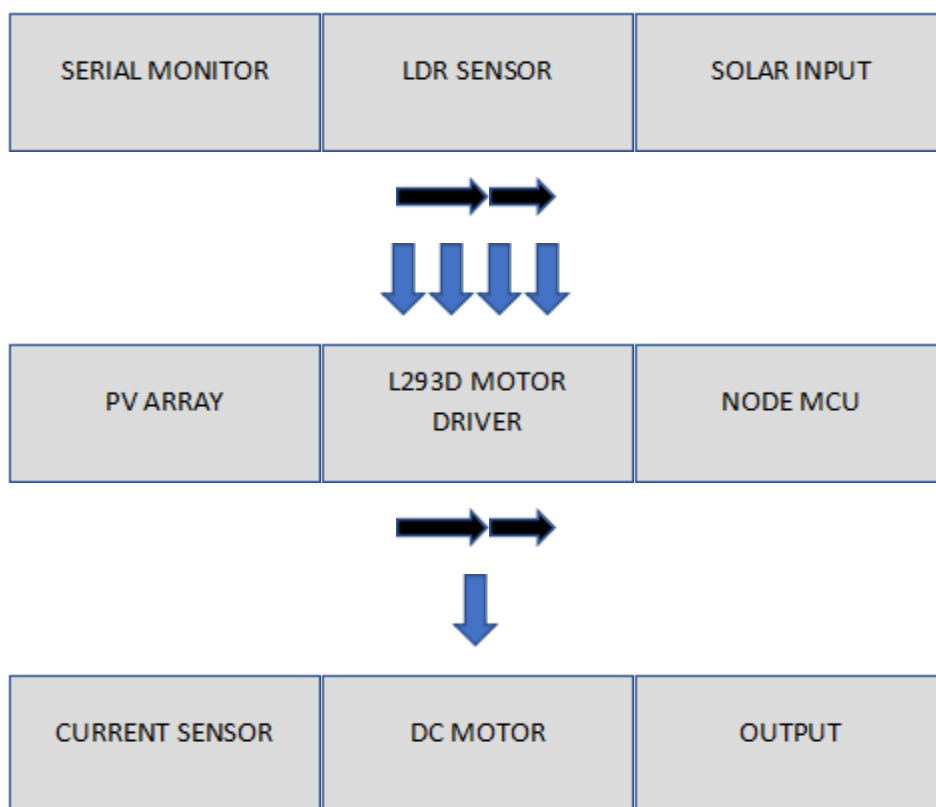

Stage consists of two LDR module which is organized in a manner of design the voltage divider circuit. By using the Arduino IDE, the microcontroller gets modified as such to match up with framework required which drive the DC motor to turn as such the direction of sunlight is falling.

The driver motor is consisting of three terminals amongst which two input are engaged for the driver supply terminals and remaining one is for the power input. Amongst the pins of the microcontroller are used for the purpose for sending information to motor driver. Framework consist of two LDR sensor modules which are used as a simple source of information for NodeMCU. A light dependent resistor is placed along the length of one or the other side of the solar based charger.

Fig. 2 Concept of using two LDR

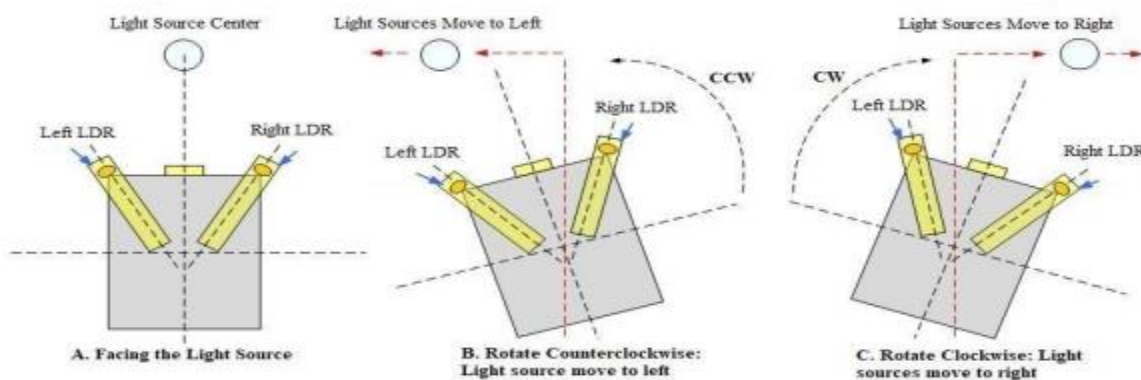

CONCLUSION

Civilization totally depends upon the energy as its primary source which controls to compensate the uncontrolled efficiency of the system. Since it is said that energy cannot be created or extinguished, this reaction tends to be implied to be rather tidy. In order to verify such objectivity, this company has attempted to perfect the path to such objectivity. The steady use of energy in some way often paves the way for natural resource scarcity. The Sun, on its pedestal, is the supreme source that has been dotting the entire cosmos since the beginning when life was contemplated, and is the essential and mother source of relatively numerous energies. The company was closed, considering that such an energy-wasting point is very large. Non-solar energy is an interaction that occurs through the consumption of various substances, including the release of many impurities, which degrade the climate and air daily. The present perceptibility is easy access to each and every circle of life which requires intense lightness is achieved by speed and cleverness, above which the energy to the ultimate of the proposal is behind it all. A difficult task that exists. In this regard, it is important to realize that we somehow exist in a fierce pool of ignorance about the global shortage of wealth that results from the need for money and power to fling too far for commercialization and hurt the whole world. It would be more worthwhile to clarify. Fixing the world is the premise sought by time clocks, so that this effort will reduce the amount of pollution that is isolated from the sun while storing energy.

FUTURE SCOPE

The true epitome of being able to solve advanced problems is a company called "Programmed Solar Tracking System". This framework is a pioneer in his soul, and it brings him to the best of his ability in terms of financial situation and openness. In the haze of smoke where pollution overwhelms each progress circle for production capacity, this device is progressing and progressing in its very effective way by sweeping the pollution out of the way.

REFERENCES

- [1] Ying-Tung Hsiao, China-Hong Chen, "Maximum Power Tracking for Photovoltaic Power System," Conference Record of the 2002 IEEE Industry Applications Conference. 37th IAS Annual Meeting, ISBN-0-7803-7420-7, 13-18 Oct, 2002, pp 1035-1039.
- [2] Mayank Kumar Lokhande, "Automatic Solar Tracking System," International Journal of Core Engineering & Management, October, 2014.
- [3] Scott J Hamilton, "Sun-Tracking Solar Cell Array System," University of Queensland, Department of Electrical Engineering, 1999
- [4] Furkan Dincer, Mehmet Emin Meral, "Critical Factors that Affecting Efficiency of Solar Cell," University of Yuzuncu Yil, Department of Electrical and Electronics Engineering, Van, Turkey, 2010.
- [5] ASHISH POLKE, Prasanna Titarmare, Rahul Dekate, Shital Yende, Mohit Gharat, Ankit Virulkar, Brijesh Ukey, & Pravin Mankar. (2021). Smart Fault Detection of Transmission Line. International Journal Of Advance Research And Innovative Ideas In Education, 7(3), 2895-2898.
- [6] R.Z. Wang, T.S. Ge, "Advances in Solar Heating and Cooling," Woodhead Publishing, 2016, Pages 81-93, ISBN 9780081003015,
- [7] Prasanna P. Titarmare, Yugal Rehpade, Swapnil Narule, Rahul Talmale, Nitin Hirekhan, & Suraj Lende. (2021). THE WIRELESS POWER TRANSMISSION SYSTEM. International Journal Of Advance Research And Innovative Ideas In Education, 7(2), 1388-1393.
- [8] Levent Bas, "Thin Film vs. Crystalline Silicon PV Modules," December, 2011.
- [9] Priyanka Gaurkhede, Prasanna Titarmare, ASHISH POLKE, Rahul Dekate, Prajwal Doye, Rohan Guru, Nikhil Buwade, & Alpesh khedikar. (2021). RESEARCH PAPER ON GSM BASED VEHICLE FUEL MONITORING AND THEFT DETECTION SYSTEM WITH SMS INDICATION. International Journal Of Advance Research And Innovative Ideas In Education, 7(3), 2931-2935
- [10] Niru Khobragade, Dr. Ashtashil Bhambulkar, & Dr. Rahul Kumar Chawda (2022) Compressive Strength Of Concrete Block Tested: FEA Method. International Journal of Mechanical Engineering, 7 (4), 1572-1580.
- [11] M. A. Panait, T. Tudorache, "A Simple Neural Network Solar Tracker for Optimizing Conversion Efficiency in Off-Grid Solar Generators", International Conference on Renewable energies and Power quality (ICREPQ), march 12-14, Santander, 2008.
- [12] Ganorkar, R. A., Rode, P. I., & Bhambulkar, A. V. (2013). Application Of Gis In Transportation Engineering. International Journal of Engineering Research and Applications (IJERA), 3(2).
- [13] Juan Reca-Cardena, Rafael López-Luque, Chapter 9- Design Principles of Photovoltaic Irrigation Systems, "Advances in Renewable Energies and Power Technologies", Elsevier Science, 2018
- [14] C. Chang, Chapter 5 Tracking solar collection technologies for solar heating and cooling systems, "Advances in Solar Heating and Cooling", Woodhead Publishing, 2016.

- [15] Khobragade, Bhambulkar, Dr., & Chawda, Dr. (2022). COMPRESSIVE STRENGTH OF CONCRETE BLOCK TESTED: FEA METHOD. International Journal of Mechanical Engineering, 7(4), 1572–1580. Retrieved from https://kalaharijournals.com/resources/APRIL_191.pdf.
- [16] Kamrul Islam Chowdhury, Md.Iftekhur-ul-Alam, Promit Shams Bakshi, “Performance Comparison Between Fixed Panel, Single-axis and Dual-axis Sun Tracking Solar Panel System,” BRAC University, Department of Electrical and Electronic Engineering, 2017.
- [17] Bhambulkar, A., & Khedikar, I. P. (2011). Municipal solid waste (MSW) collection route for Laxmi Nagar by geographical information system (GIS). International Journal of Advanced Engineering Technology, 2(4), 1-6.
- [18] Oloka Reagan Otieno, “SOLAR TRACKER FOR SOLAR PANEL”, University of Nairobi, Dept. of Electrical and Electronic Engineering, 24th August 2015.