

An Approach to Promote Digi-Learning Structure all Through COVID-19 Outbreak Conditional Study to Assess the Students' Fraternity

G. Arasuraja¹, S. Vijayakanthan²

¹Department of Management Studies, St. Joseph's Institute of Technology, OMR, Chennai, TamilNadu, India

²Department of Management Studies, SRM Institute of Science and Technology, Vadapalani, Chennai, TamilNadu, India

Email: arasuraja.mba@gmail.com

DOI: 10.47750/pnr.2022.13.S01.83

Abstract

Globally, the pandemic situation has compelled educational institutions to rally behind efforts to contain the spread of this virus. Throughout this lockdown, these occurrences prompted educational experts to consider unorthodox ways of instruction. Thus, it paved the path for digital learning. This research will assist with determining how students feel about digital classes and tests during the COVID-19 Pandemic. It was compiled using information received from students at various colleges/universities/institutions located throughout Tamil Nadu.

Keywords: COVID-19, Digi-Learning, Students' Fraternity.

INTRODUCTION

S Education's objective is to mould a person into a wonderful person. It paves the route for their future success and instills social duties. The primary goal of education is to expand one's mind and acquire information. Learning is the process through which individuals acquire information or skills via study, experience, or instruction. Any chance event that occurs in the world will always have an effect on education, and the COVID 19 outbreak has had an effect on education. Globally, the pandemic crisis has compelled educational institutions to close in order to contain the virus's spread. These occurrences prompted educators to consider alternate means of coaching during the lockdown. As so, it paves the way for web-based education. Today's learning environment has migrated to the digital realm. In which educators and pupils are digitally linked. E-learning is a very straightforward concept to grasp and apply. A significant component of this learning style is the usage of a desktop, laptop, smart phone, and the internet. E-learning has had fast development and has shown to be the most effective in all areas, particularly education, during this period of lockdown. The purpose of this survey is to ascertain students' perceptions about online classes and assessments during the COVID-19 Pandemic. It was done for the benefit of students enrolled in various universities and to demonstrate the value of e-learning during this epidemic. It may be a teaching method used in educational institutions to help students improve their knowledge and abilities via the use of digital technology. Government and educational institutions must provide a more robust infrastructure for online education for the benefit of students.

REVIEW OF THE LITERATURE

Ishmirakha Handique Konwar [6] discovered that students who utilised e-learning as a learning strategy earned higher scores or percentages than students who did not use e-learning as a learning strategy.

Obaid Ullah [9] discovered no significant association between computer students' interests and the acquisition of information through online learning at the undergraduate level in his study "Students' Attitude Toward Online Learning at Tertiary Level."

Habboush, Nassuora & Hussein [4] developed an integrated model to predict the acceptance of mobile learning by university students.

Nassuora [8] analysed that acceptance level of students on m-Learning is in the high level.

Michelle Fong [7] discovered that male students who choose online learning technologies place a lower premium on

communication chances than female students.

El-Hussein [2] explained that any type of learning that takes place in learning environments and spaces that take account of the mobility of technology, mobility of learners and mobility of learning.

Paul [10] stated that the use of online e-learning by members of educational communities is increasing.

Blagovesna Yovkova (2018) [12] discovered that students had a resoundingly favourable attitude toward online distance learning in his research "Factors determining students' attitudes toward online learning." Education consistently implies that they are more receptive to it.

STATEMENT OF THE PROBLEM

Gurukulam is a form of schooling system that existed in ancient India, with shishya living in the same house as the guru. Today, the phrase is also used to describe residential monasteries or schools run by contemporary gurus, with college as the next stage of study. A college or university is an institution of higher education for those who have completed twelve years of elementary school and wish to acquire more advanced information and get a degree to demonstrate this. Major global events frequently serve as an infectious vector for fast innovation. Online education is one of the few areas that has not had a decline in investment following COVID 19; it is one of the few sectors that has not seen a decline in investment. The epidemic has demonstrated the critical nature of knowledge dissemination across borders, companies, and all segments of society. If internet technology has a role to play in this, it is incumbent upon all of us to fully examine it. For individuals who do have access to the appropriate technology, there is evidence that online education can be more successful in a variety of ways.

The efficiency of online learning varies by age group, particularly among children. Online education has been demonstrated to improve knowledge preservation and speed up the learning process, implying that the alterations brought about by the corona virus may be permanent. Online education comes in an array of styles and sizes. Students have an infinite number of opportunities to expand their knowledge. The purpose of this study was to ascertain students' willingness to use an e-learning system during a COVID-19 paramedic situation.

OBJECTIVES OF THE STUDY

1. To ascertain the respondents' demographic characteristics.
2. To determine the influence of Enabling Conditions, Social Influence, and Expected Performance on Actual Usage.
3. The Effect of Facilitating Conditions, Actual Use, and Expected Performance on the Quality of Learning
4. To ascertain the effect of e-learning on the quality of learning.

RESEARCH METHODOLOGY

The study used a descriptive research methodology to ascertain students' attitudes on utilising an e-learning system during a COVID-19 paramedic scenario. The validity of any study is contingent upon a systematic approach to data collection and analysis. The current study collected and evaluated both secondary and primary data. A total of 240 samples were chosen using practical sampling approaches.

LIMITATIONS OF THE STUDY

The current study is limited to the Virudhunagar district. The respondents' responses may be biased, which may distort the genuine image of the research issue. The respondents who are enrolled in colleges were chosen as the sample unit. The results of the survey may differ in other areas, depending on the respondents' preferences.

ANALYSIS AND INTERPRETATION

Percentage analysis is a descriptive statistical technique used to characterise the sample or population as a whole. Percentage analysis entails calculating values for the variables under examination.

TABLE 1. Details of Demographic Information

Parameter	Observed Statistics	Implication
Gender	Male (23.3 %) and Female (76.7 %)	Respondents were selected from Male and Female to know their intention towards e-learning
Discipline	Arts (65.8%) and Science (34.2%)	Respondents from different discipline were selected to know their intention towards e-learning
Device used for e-learning	Smart Phone (88.3%) Laptop (11.7%)	Device used for e-learning details were collected to know quality of learning

Source: Primary Data

The above table interpret most of the respondents are female, Arts Students and Using Smart Phone for e-learning.

MEASUREMENT MODEL

The measurement model specifies the relationships that suggest how measured variables represent a construct that is not measured directly [5].It was assessed with confirmatory factor analysis (CFA) using the AMOS 23.0 tool to examine convergent and Discriminant validity.

TABLE 2. Results of Measurement Model

CONSTRUCTS	LOADING	CR	AVE	MSV
Performance Expectancy	PE	0.774	0.547	0.990
E-learning is useful to score high marks	0.43			
E-learning would increase understanding of Subject	0.57			
E-learning would improve my performance	0.74			
E-learning allows choosing topics to learn preferred topic.	0.64			
Social Influence	SI	0.798	0.537	1.191
Teacher, Parents and Friends influence use E-learning System	0.70			
Using E-learning System are considered to be smart	0.49			
Facilitating Condition	FC	0.725	0.599	1.191
Have enough resources to use the E-learning System	0.68			
Have the knowledge necessary to use the E-learning System	0.61			
Training is given to use E-learning System	0.68			
E-learning System is compatible with other technologies	0.58			
Actual Usage	AU	0.793	0.566	0.863
The use of E-Learning System has become a habit	0.86			
Plan to continue using E-Learning frequently after regular classes	0.77			
Use the E-learning system a lot to course work	0.63			
Quality of Learning	QL	0.769	0.527	0.863
E-Learning System helps for creative thinking	0.72			
E-Learning System provide more opportunities to participate in the class discussion	0.59			
E-Learning System trends to excel in the quality of learning to acquire Knowledge	0.71			

Source: Computed Data

CR- Composite Reliability, AVE-Average Variance Extracted, MSV- Maximum Shared Variance

TABLE 2describes the results of measurement model. Convergent validity is ascertained by examining indicator loadings. In this study, factor loading values were above 0.4 (Acceptable range) that indicates the validity of the construct. The convergent validity was also confirmed through estimation of average variance extracted (AVE) as recommended by Fornell and Larcker [3], values must be greater than 0.5. Finally, composite reliability was assessed and all values exceeded 0.5.

TABLE 3. Discriminant validity of measurement model

	SI	FC	PE	AU	QL
SI	0.911*				
FC	0.791	0.932*			
PE	0.691	0.695	0.899*		
AU	0.810	0.831	0.876	0.953*	
QL	0.846	0.844	0.871	0.729	0.926*

Source: Computed Data

*Diagonal elements (bold) are Square Root of AVE

Off diagonal elements present binary correlation among the construct

Correlation and square root of AVE values used to determine the discriminant validity of the online shopping concept. According to Fornell and Larcker [3], the square root of the average variance extracted (AVE) for each sub construct should be greater than the correlation coefficient between sub constructs. There is a correlation between Facilitating Conditions and Social Influence (0.791), between Performance Expectancy and Social Influence (0.691), between Performance Expectancy and Facilitating Conditions (0.695), between Actual Usage and Social Influence (0.810), between Actual Usage and Facilitating Conditions (0.831), between Actual Usage and Performance Expectancy (0.876), between Quality of Learning and Social Influence (0.846), between Quality of Learning and Facilitating Conditions (0.844), and between Quality of Learning and Performance Expectancy (0.876 (0.729)). As a result, the square root of AVE is always greater than the correlation.

CFA Model with Standardized Factor Loading

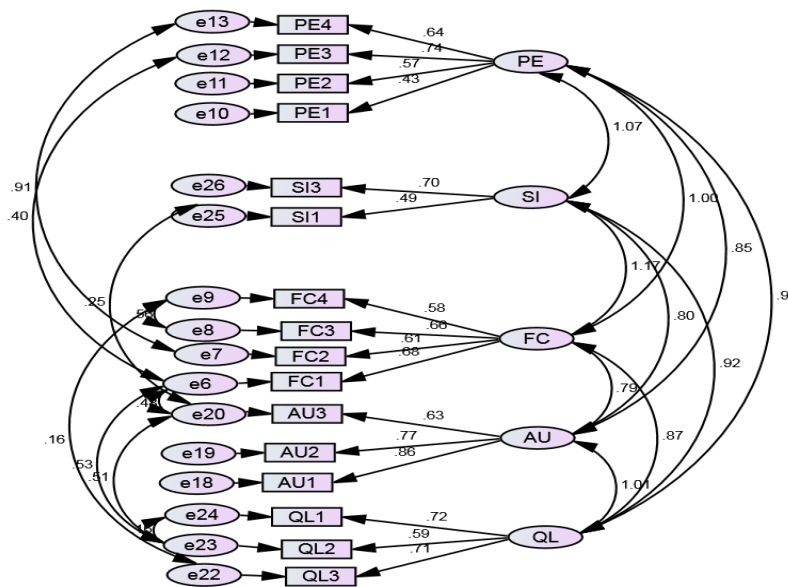

According to the CFA model, Performance Expectancy, Social Influence, Facilitating Conditions, Actual Usage, and Quality of Learning are statistically significant, implying that Performance Expectancy has a significant impact on Social Influence, Facilitating Conditions, Actual Usage, and Quality of Learning. Social influence has a major impact on performance expectations, enabling conditions, actual usage, and learning quality. Actual Use has a large impact on Performance Expectancy, Social Influence, Facilitating Conditions, and Learning Quality. The quality of learning has a substantial impact on performance expectations, social influence, enabling conditions, and actual use. All indicators in the measurement model have factor loading values more than 0.43, which is within the permitted range of greater than 0.4.

GOODNESS OF FIT TEST

The recommended approach to judging the adequacy of a model is to use several fit indices. A model can be considered to have adequate fit if most or all fit indices are acceptable.

TABLE 4. Goodness of Fit test of Path Analysis

Measures	Estimate	Threshold	Interpretation
CMIN	164.541	--	--
DF	99	--	--
CMIN/DF	1.662	Between 1 and 3	Excellent
CFI	0.967	>0.95	Excellent
SRMR	0.070	<0.08	Excellent
RMSEA	0.061	<0.06	Acceptable
PClose	0.138	>0.05	Excellent

Source: Computed Data

Studies were conducted to examine the sensitivity of goodness of fit indexes to lack of measurement invariance at 3 commonly tested levels: factor loadings, intercepts, and residual variances. Standardized root mean square residual (SRMR) appears to be more sensitive to lack of invariance in factor loadings than in intercepts or residual variances[1]. The value of CMIN/DF, CFI, SRMR, RMSEA are 1.662, 0.967, 0.070, 0 and 0.061 respectively. The minimum fit chi-square statistic was found to be significant (Chi square = 164.541;df= 99; p = 0.138), therefore, could be considered as a perfect model fit and implied that the model might adequate.

TESTING THE PATH AND HYPOTHESES

Relationships between theoretical constructs are expressed in structural equation modelling by regression or path coefficients between the constructs. The single-headed arrows illustrate the model's causal link, with the variable at the tail of the arrow serving as the cause of the variable at the point. Single-headed arrows depict the regression coefficients statistically.

Path Diagram of the Model with Standardized Regression Weight

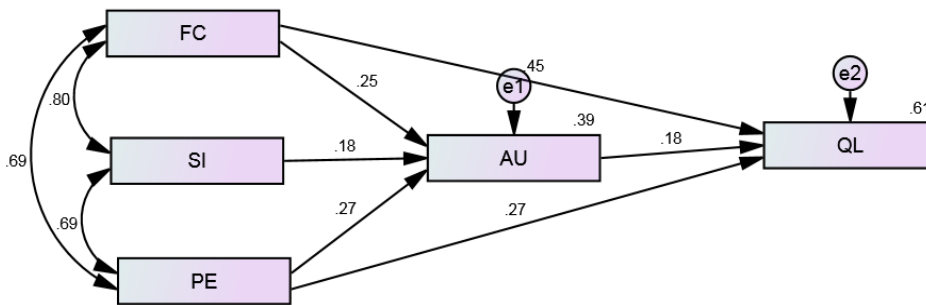

TABLE 5. Regression Weights

Relationships between Exogenous and Endogenous	Estimate	S.E.	C.R.	P	Relationship
AU <--- FC	0.053	0.019	2.831	.005	Significant
AU <--- SI	0.074	0.037	2.015	.044	Significant
AU <--- PE	0.051	0.014	3.650	***	Significant
QW <--- AU	0.364	0.103	3.538	***	Significant
QW <--- FC	0.192	0.025	7.754	***	Significant
QW <--- PE	0.103	0.022	4.646	***	Significant

Source: Computed Data

The relationships between different variable are measured through the unstandardized regression coefficient (β). In the table the unstandardized regression coefficient (β) shows that when exogenous variable (independent variable) goes up by 1 unit, the endogenous variable (dependent variable) goes up by the unit of its respective estimate (Jana & Chandra, 2016) [11]. The further explanation of relationships is given below.

Effect of Facilitating Conditions, Social Influence and Performance Expectancy on Actual Usage

H01: There is no evidence that Facilitating Conditions, Social Influence, or Performance Expectancy have a substantial influence on actual usage.

The critical ratio, regression coefficient, and p value are 2.831, 0.053, and 0.005 for the path from Facilitating Conditions to Actual Usage, respectively. The path from Social Influence to Actual Usage has a critical ratio of 2.015, a regression coefficient of 0.074, and a p value of 0.044, respectively. The path from Performance Expectancy to Actual Usage has a critical ratio of

3.650, a regression coefficient of 0.051, and a p value of 0.001, respectively. As the p value is smaller than the significant alpha value of 0.05, Ho1 is rejected as having a significant positive effect on Actual Usage. When Facilitating Conditions, Social Influence, and Performance Expectancy all increase by one, Actual Usage increases by 0.25, 0.18, and 0.27.

Effect of Facilitating Conditions, Actual Usage and Performance Expectancy on Quality of Learning

Ho2: There is no evidence that Facilitating Conditions, Actual Usage, or Performance Expectancy have a substantial influence on the quality of learning. The crucial ratio, regression coefficient, and p value for the path from Actual Usage to Learning Quality are respectively 3.538, 0.364, and 0.001. The crucial ratio, regression coefficient, and p value for the path from Facilitating Conditions to Learning Quality, respectively, are 7.754, 0.192, and 0.001. The crucial ratio, regression coefficient, and p value are 4.646, 0.103, and 0.001 for the path from Performance Expectancy to Quality of Learning, respectively. Because the p value is smaller than the significant alpha value of 0.05, the hypothesis that Facilitating Conditions, Actual Usage, and Performance Expectancy all have a significant positive effect on Learning Quality is rejected. When Facilitating Conditions, Actual Usage, and Performance Expectancy all increase by one, the resulting increase in the quality of learning is 0.45, 0.18, and 0.27, respectively.

TABLE 6. Effect of Independent Variables on Dependent variable

Dependent Variable	Independent Variable	Direct Effect	Indirect Effect	Total Effect	R ²
Actual Usage	Facilitating Conditions	0.250	0.000	0.250	0.39
	Social Influence	0.179	0.000	0.179	
	Performance Expectancy	0.266	0.000	0.266	
Quality of Learning	Facilitating Conditions	0.449	0.045	0.494	0.61
	Social Influence	0.000	0.032	0.032	
	Performance Expectancy	0.266	0.048	0.314	
	Actual Usage	0.180	0.000	0.180	

On actual usage, the standardised total direct impacts of Facilitating Conditions, Social Influence, and Performance Expectancy are 0.250, 0.179, and 0.266, respectively. On the quality of learning, the standardised total impacts of Facilitating Conditions, Social Influence, Performance Expectancy, and Actual Use are 0.494, 0.032, 0.314, and 0.180, respectively. According to the squared multiple correlation, the predictors of Actual Usage account for 39% of its variation, whereas the predictors of Learning Quality account for 61% of its variance.

SUGGESTIONS

The researcher makes the following recommendations to enhance the influence of e-learning on learning quality.

1. Educational institutions may employ open book examinations to help students improve application and analytical abilities in the event of a Covid 19 pandemic.
2. Teachers may employ presentation software to enhance the interactive nature of online classes.
3. Workshops for rural students to improve their understanding of the e-learning system may be offered.
4. Through the Flipped Class Room, teachers may provide more possibilities for students to participate actively.
5. The Tamil Nadu government may continue to provide free laptops to impoverished students in order to increase their interest in e-learning.

CONCLUSION

E-learning systems are extremely beneficial during times of lockdown limitations. Online classes are successfully taught and learned. Students feel that offline classes are superior to online ones, yet they are comfortable with the E-learning method. The poll elicited several fascinating responses, such as the fact that the majority of students have their own mobile phone and laptop for attending online classes. The majority of students utilise headphones when taking online classes. Overall, pupils are likely to favour an e-learning system in the future.

REFERENCES

1. Chen, F.F. (2007) "Sensitivity of Goodness of Fit Indexes to Lack of Measurement Invariance". *Structural Equation Modeling: A Multidisciplinary Journal*, vol.14, pp.464–504.
2. El-Hussein, M. O. M., & Cronje, J. C. (2010), "Defining Mobile Learning in the Higher Education Landscape." *Educational Technology & Society*, vol. 13, pp. 12–21.
3. Fornell, C., & Larcker, D. F. (1981), "Evaluating Structural Equation Models with Unobservable Variables and Measurement Error". *Journal of Marketing Research*, vol.18, pp.39 – 50.
4. Habboush, A., Nassuora, A., & Hussein, A.R. (2011), "Acceptance of Mobile Learning by University Students". *American Journal of Scientific Research*, vol.22, pp.119–122.
5. Hair, J., Blake, W., Babin, B., and Tatham, R. (2006). *Multivariate Data Analysis*. New Jersey: Prentice Hall.
6. Ishmirekha Handique Konwar1. (2017), "A Study on Attitude of College Students towards E-learning with Special Reference to North Lakhimpur of Lakhimpur District", *Assam International Journal of Information Science and Education*. ISSN 2231-1262 Vol 4, No pp. 1-9
7. Michelle Fong (2014), "Student attitudes to traditional and online methods of delivery", *Journal of Information Technology Education: Vol 13*,
8. Nassuora, A. B. (2012), "Student Acceptance of Mobile Learning for Higher Education". *American Academic & Scholarly Research Journal*, vol.4, pp.0–5.
9. Obaid Ullah, (2017), "Students Attitude towards Online Learning at Tertiary Level", *PUTAJ – Humanities and Social Sciences*, Vol.25, No.1-2 (Special Issue-Media Matters), p.78
10. Paul G. Paris, (2004) "E-Learning: A study on Secondary Students' Attitudes towards Online Web Assisted learning", *International Education Journal*, Vol 5, No 1, p. 111
11. Jana, A., & Chandra, B. (2016). Mediating role of customer satisfaction in the mid-market hotels: An empirical analysis. *Indian Journal of Science and Technology*, 9(1), 1-16.
12. Roumiana Peytcheva-Forsyth., Blagovesna Yovkova., Lyubka Aleksieva (2018), "Factors Affecting Students' Attitudes Towards Online Learning - The Case of Sofia University" *AIP Conference Proceedings 2048*, 020032 (2018); Vol 2048, Issue 1, Pp: 020025-1 - 020025-8.